

DIAGRAM SUMMARY TABLE
TABELLA RIASSUNTIVA DEL QUADRO

TENSIONE NOMINALE - NOMINAL VOLTAGE V _n = 400V 3F+N
FREQUENZA - FREQUENCY f = 50/60Hz
POTENZE E CORRENTI : POWER AND CURRENT :
PROVENIENZA E TIPO LINEE ALIMENTAZIONE : ORIGIN AND TYPE OF POWER SUPPLY LINES :
STRUTTURA DEL QUADRO : PANEL STRUCTURE :
GRADO DI PROTEZIONE MINIMO : MINIMUM PROTECTION LIMIT :

ATTENZIONE !
FILI E COMPONENTI TRATTEGGIATI
SONO OPZIONALI.
VERIFICARE SE SONO INSTALLATI

CAUTION !
WIRES AND SECTIONED COMPONENTS
ARE OPTIONALS.
VERIFY IF THEY ARE INSTALLED

NR. FOGLIO-SHEET NR.	TITOLO-TITLE
1	ALIMENTAZIONE GENERALE-GENERAL POWER SUPPLY
2	MOTORI-MOTORS
3	MOTORE ASCIUGATURA-DRYER MOTOR
4	RESISTENZE-HEATING ELEMENTS
5	AUSILIARI-AUXILIARI
6	LAY-OUT SCHEDE ELETTRONICHE-LAY-OUT ELECTRONIC BOARDS
7	STAMPANTE-PRINTER
8	INGRESSI SCHEDE-BOARD INPUTS - 6A1
9	USCITE SCHEDE-BOARD OUTPUTS - 6A1
10	USCITE SCHEDE-BOARD OUTPUTS - 6A1
11	USCITE SCHEDE-BOARD OUTPUTS - 6A1
12	INGRESSI SCHEDE-BOARD INPUTS - 6A1
13	INGRESSI SCHEDE-BOARD INPUTS - 6A1
14	INGRESSI SCHEDE-BOARD INPUTS - 6A1
15	INGRESSI SCHEDE-BOARD INPUTS - 6A1
16	INGRESSI SCHEDE-BOARD INPUTS - 6A1
17	INGRESSI SCHEDE-BOARD INPUTS - 6A1
18	INGRESSI SCHEDE-BOARD INPUTS - 6A1
19	LIBERA
20	INGRESSI SCHEDE-BOARD INPUTS - 6A2
21	USCITE SCHEDE-BOARD OUTPUTS - 6A2
22	USCITE SCHEDE-BOARD OUTPUTS - 6A2
23	USCITE SCHEDE-BOARD OUTPUTS - 6A2
24	INGRESSI SCHEDE-BOARD INPUTS - 6A2
25	INGRESSI SCHEDE-BOARD INPUTS - 6A2
26	INGRESSI SCHEDE-BOARD INPUTS - 6A2
27	INGRESSI SCHEDE-BOARD INPUTS - 6A2
28	INGRESSI SCHEDE-BOARD INPUTS - 6A2
29	INGRESSI SCHEDE-BOARD INPUTS - 6A2
30	INGRESSI SCHEDE-BOARD INPUTS - 6A2
31	LIBERO

 INTERNATIONAL STEEL CO. SPA		tavola:
cliente:		data: 04/01/2008
		scala: 1:1 mm
titolo:	LAVASTRUMENTI - WASHER DISINFECTOR DS610	agg:
		firma:
SCHEMA ELETTRICO	WIRING DIAGRAM	archivio: DS610A

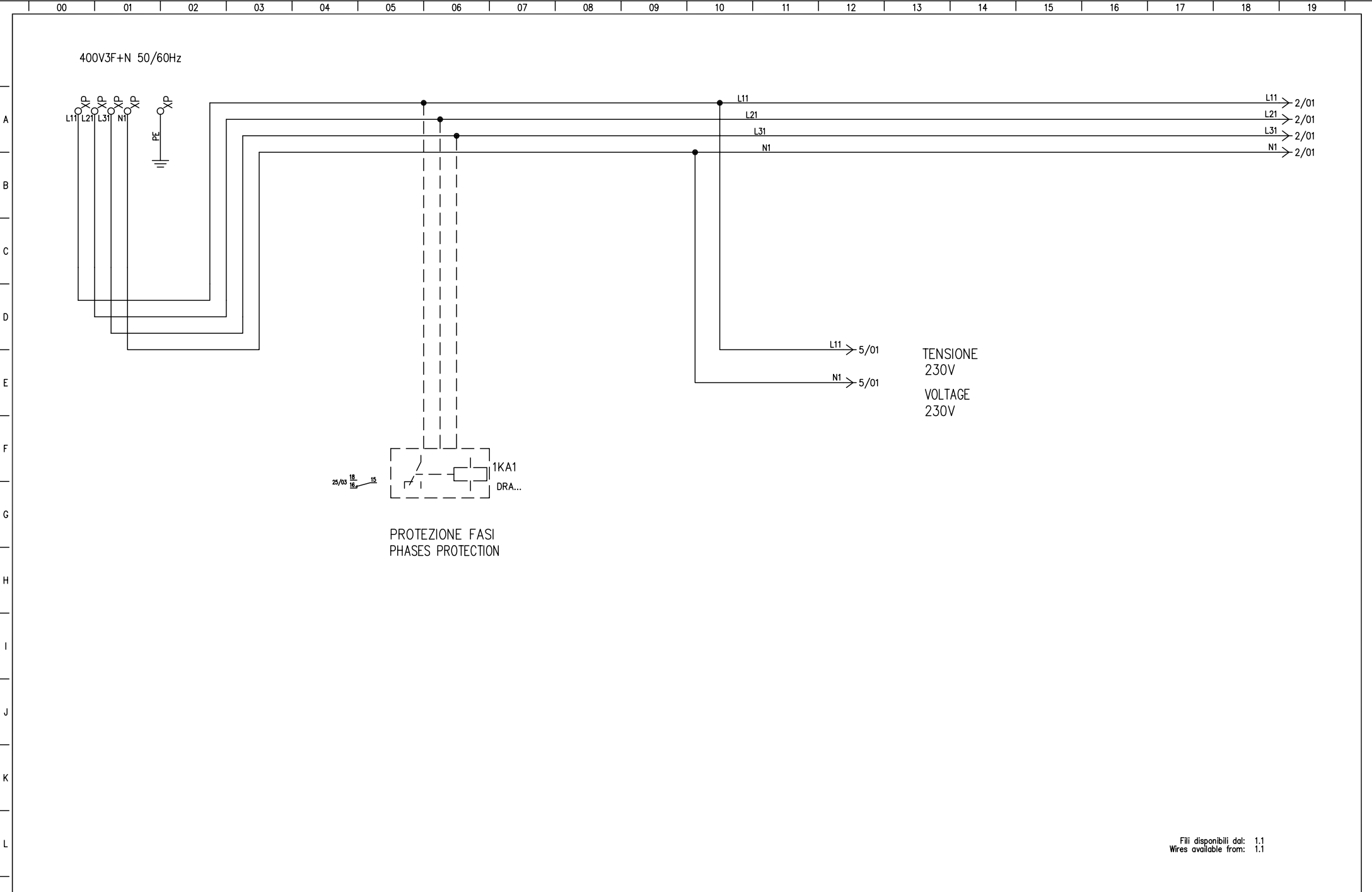

			IMPIANTO	LAVASTRUMENTI-WASHER DISINFECTOR DS610	TITOLO	ALIMENTAZIONE GENERALE-GENERAL POWER SUPPLY	DISEGNATORE		N. DIS.	DS610A.DWG	FOGLIO	1	SEGUE	2
									N. ARCH.					
					INTERNATIONAL STEEL CO s.p.a.	SCHEMA	DS610A	RIF. CLIENTE		DATA	04/01/2008	TOT. FOGLI	32	
REV.	DATA	OGGETTO MODIFICA	FIRMA		Riese Pio x (TV)			FIRMA	SCALA	1:1 mm				

IDEA R. 2007

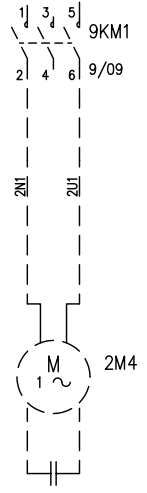
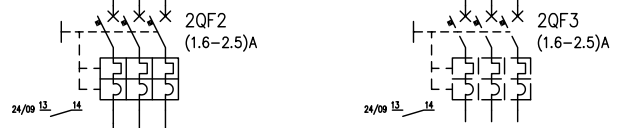
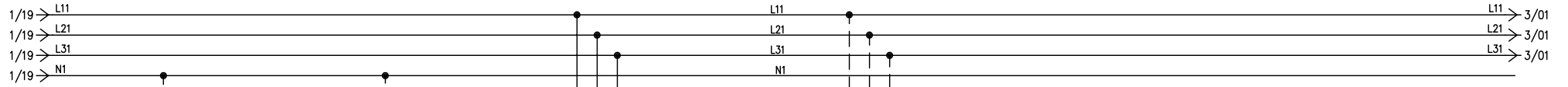

POMPA AUMENTO PRESSIONE DEMI
OPZIONALE
PRESSURE INCREASE WASHING PUMP
OPTIONAL

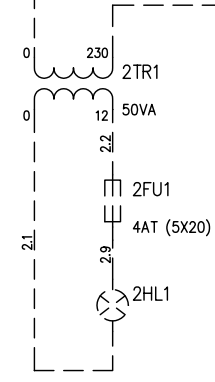

LUCE CAMERA
CHAMBER LIGHT

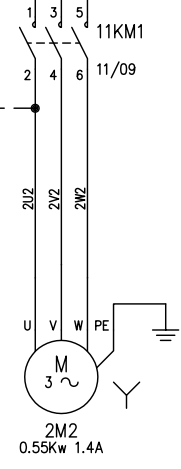

POMPA GIRANTI
WASHING ARMS PUMP

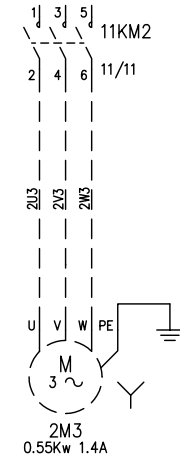

POMPA CESTI
OPZIONALE
BASKETS PUMP
OPTIONAL

Fili disponibili dal: 2.10
Wires available from: 2.10

		IMPIANTO		TITOLO		DISEGNATORE		N. DIS. DS610A.DWG		FOGLIO	SEGUE
		LAVASTRUMENTI-WASHER DISINFECTOR DS610		MOTORI-MOTORS				N. ARCH.		2	3
		INTERNATIONAL STEEL CO s.p.a.		SCHEMA		FIRMA		DATA		TOT. FOGLI	
REV.		DATA		Riese Pio x (TV)		RIF. CLIENTE		04/01/2008		32	
		OGGETTO MODIFICA						SCALA			
								1:1 mm			

IDEA R. 2007

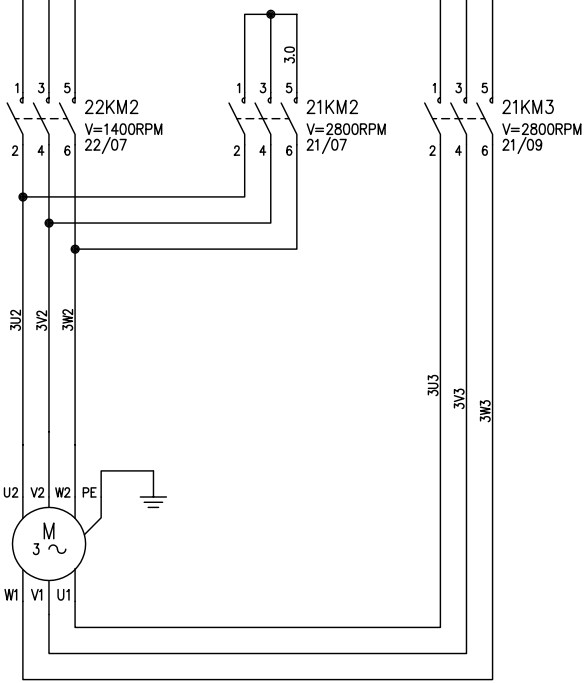
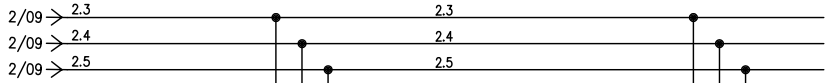
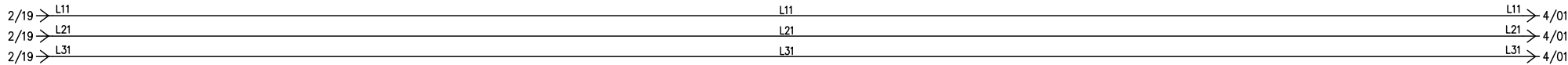

Fili disponibili dal: 3.1
 Wires available from: 3.1

			IMPIANTO	LAVASTRUMENTI-WASHER DISINFECTOR DS610	TITOLO	MOTORE ASCIUGATURA-DRYER MOTOR	DISEGNATORE		N. DIS.	DS610A.DWG	FOGLIO	3	SEGUE	4
									N. ARCH.					
					INTERNATIONAL STEEL CO s.p.a.	SCHEMA	RIF. CLIENTE	FIRMA	DATA	04/01/2008	TOT. FOGLI	32		
REV.	DATA	OGGETTO MODIFICA	FIRMA	Riese Pio x (TV)	DS610A				SCALA	1:1 mm				

IDEA R. 2007

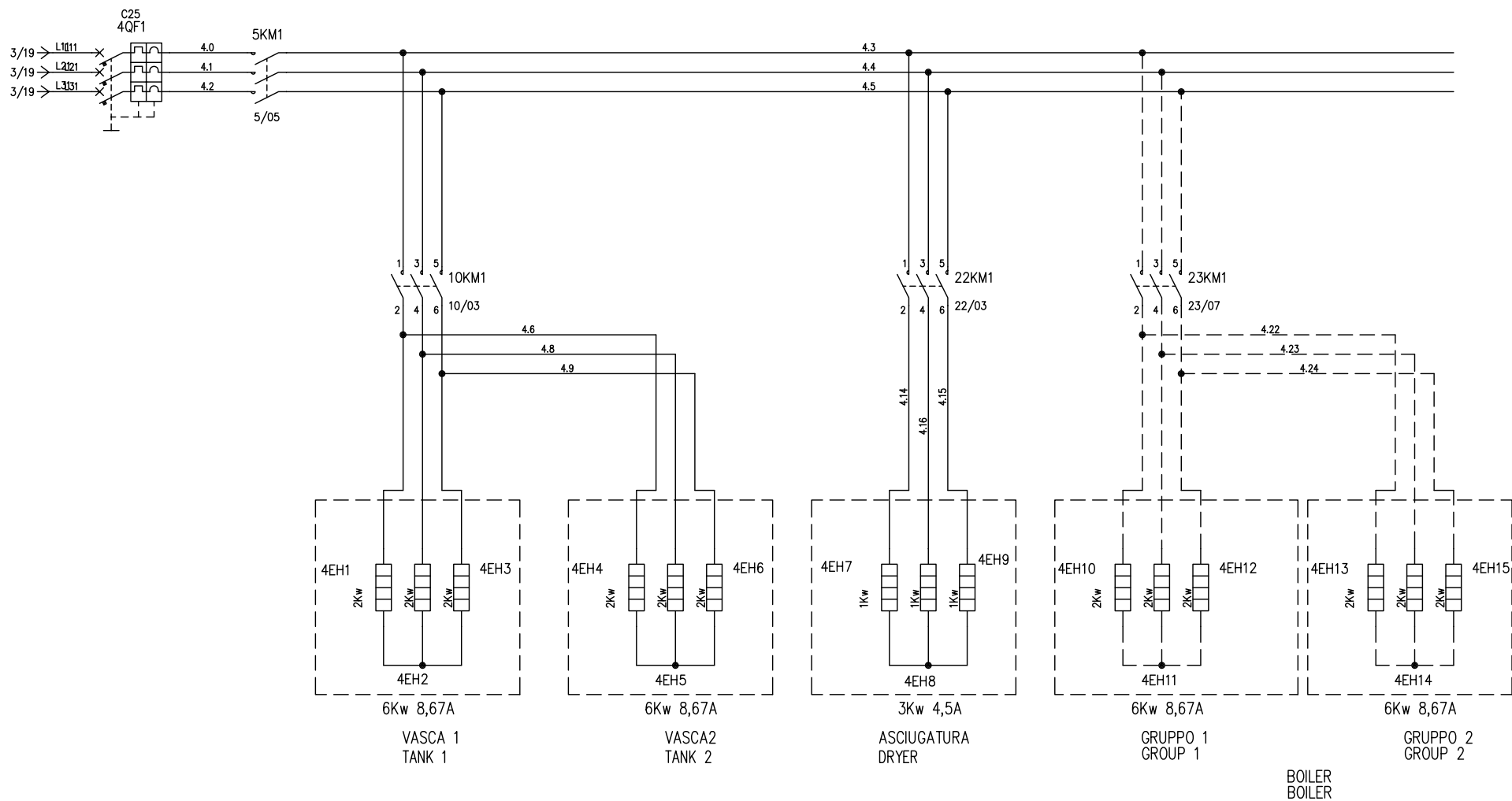

Fili disponibili dal: 4.10
Wires available from: 4.10

			IMPIANTO	LAVASTRUMENTI-WASHER DISINFECTOR DS610	TITOLO	RESISTENZE-HEATING ELEMENTS	DISEGNATORE	N. DIS.	DS610A.DWG	FOGLIO	4	SEQUE	5
								N. ARCH.					
								DATA	04/01/2008	TOT. FOGLI	32		
REV.	DATA	OGGETTO MODIFICA	FIRMA	INTERNATIONAL STEEL CO s.p.a. Riese Pio x (TV)		SCHEMA	DS610A	RIF. CLIENTE		FIRMA	SCALA	1:1 mm	

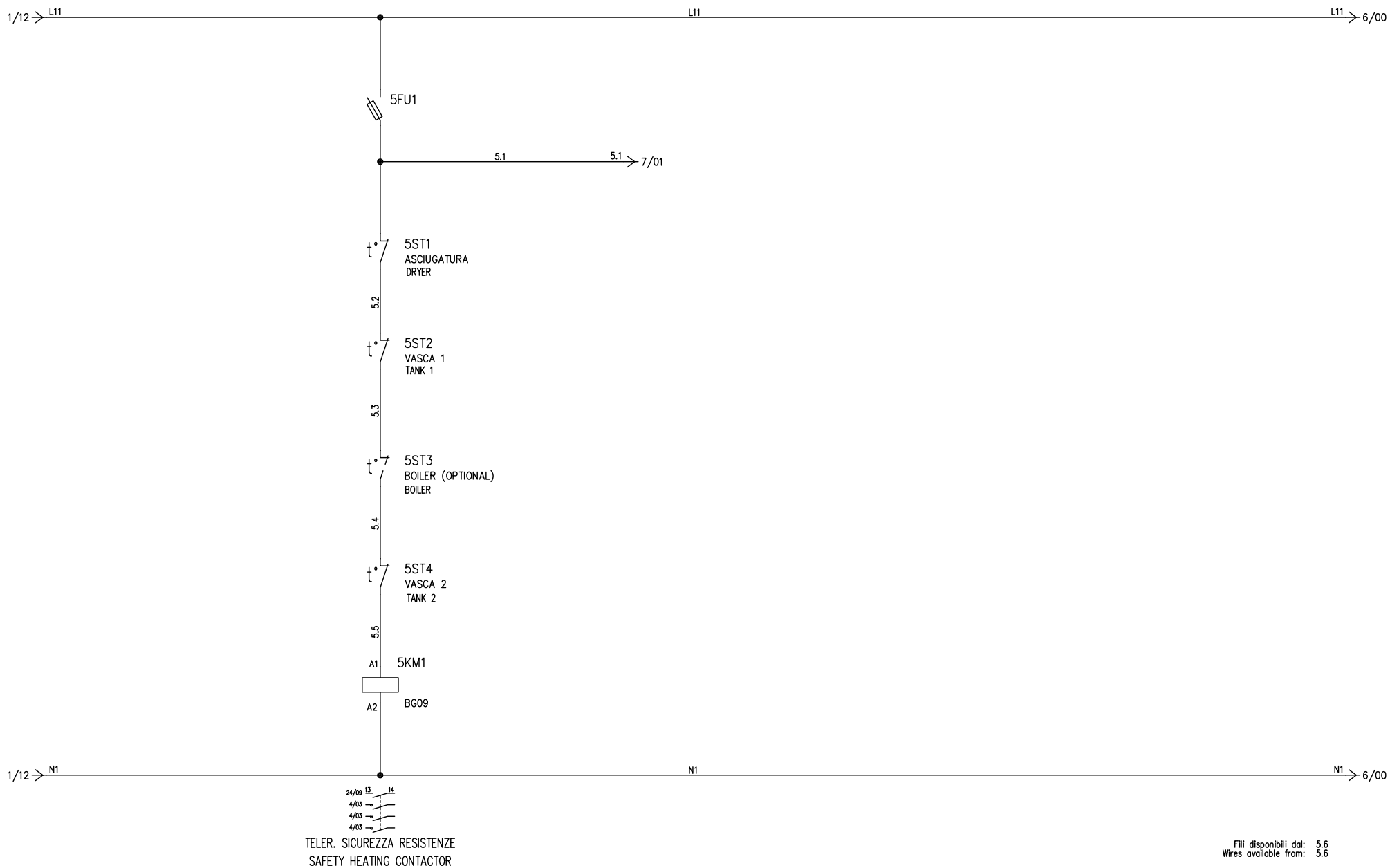

				IMPIANTO LAVASTRUMENTI-WASHER DISINFECTOR DS610	TITOLO AUSILIARI-AUXILIARI	DISEGNATORE	N. DIS. DS610A.DWG	FOGLIO 5	SEGUE 6
				INTERNATIONAL STEEL CO s.p.a. Riese Pio x (TV)	SCHEMA DS610A	RIF. CLIENTE	DATA 04/01/2008	TOT. FOGLI 32	
REV.	DATA	OGGETTO MODIFICA	FIRMA			FIRMA	SCALA 1:1 mm		

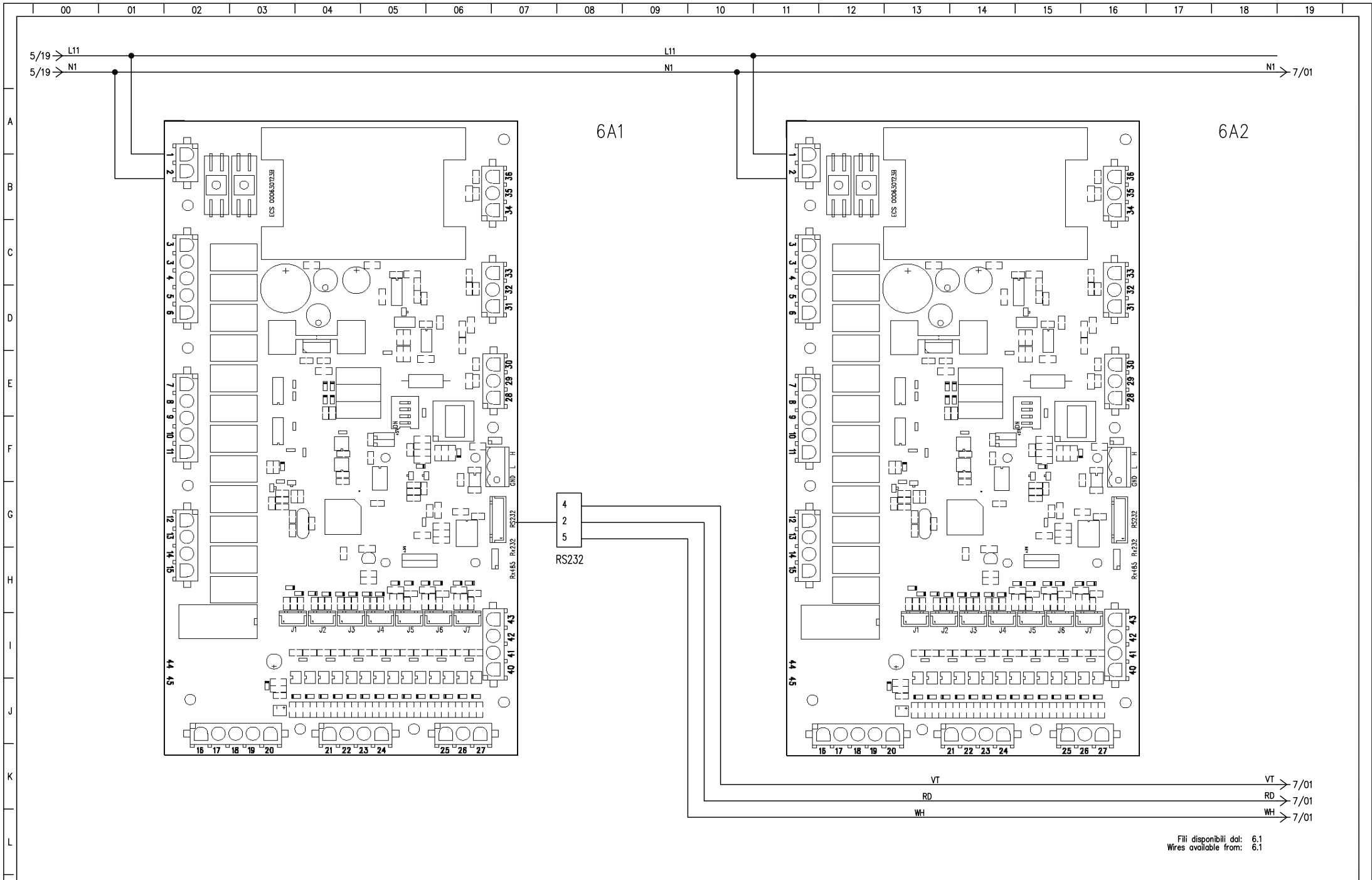

Fili disponibili dal: 6.1
Wires available from: 6.1

			IMPIANTO LAVASTRUMENTI-WASHER DISINFECTOR DS610	TITOLO LAY-OUT SCHEDE ELETTRONICHE-LAY-OUT ELECTRONIC BOARDS	DISEGNATORE	N. DIS. DS610A.DWG	FOGLIO 6	SEGUE 7
			INTERNATIONAL STEEL CO s.p.a. Riese Pio x (TV)	SCHEMA DS610A	RIF. CLIENTE	DATA 04/01/2008	TOT. FOGLI 32	
REV.	DATA	OGGETTO MODIFICA	FIRMA		FIRMA	SCALA 1:1 mm		

IDEA R. 2007

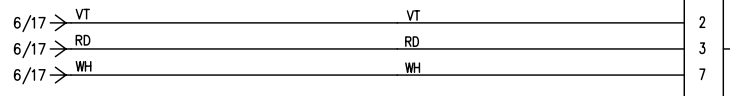
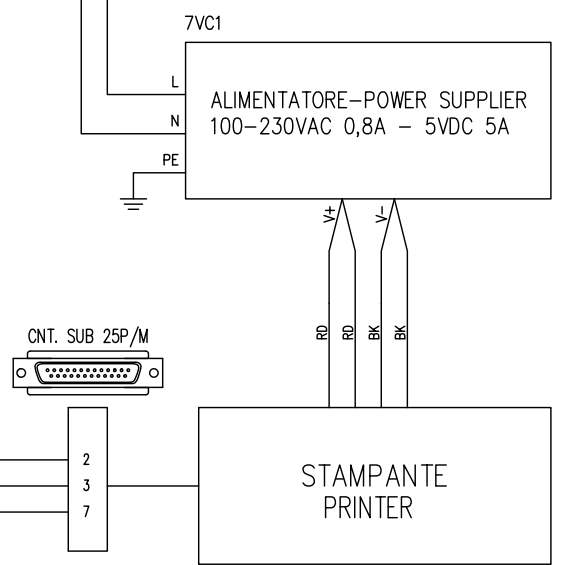
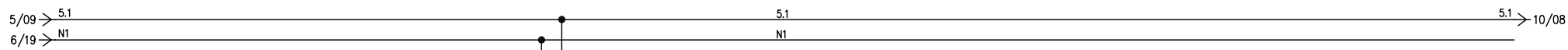

Fili disponibili dal: 7.1
Wires available from: 7.1

				IMPIANTO LAVASTRUMENTI-WASHER DISINFECTOR DS610	TITOLO STAMPANTE-PRINTER	DISEGNATORE	N. DIS. DS610A.DWG	FOGLIO 7	SEGUE 8
				INTERNATIONAL STEEL CO s.p.a.	SCHEMA DS610A	RIF. CLIENTE	DATA 04/01/2008	TOT. FOGLI 32	
REV.	DATA	OGGETTO MODIFICA	FIRMA	Riese Pio x (TV)		FIRMA	SCALA 1:1 mm		



6A1

J1	J2	J3	J4	J5	J6	J7
FLUSS. DETERGENTE ALCALINO ALKALINE DETERGENT FLOWMETER	FLUSS. DETERGENTE ACIDO ACIDE DETERGENT FLOWMETER	FLUSS. LUBRIFICANTE LUBRIFICANT FLOWMETER	FLUSS. SODA SODA FLOWMETER	LIBERO FREE	LIBERO FREE	LIBERO FREE

			IMPIANTO LAVASTRUMENTI-WASHER DISINFECTOR DS610	TITOLO INGRESSI SCHEDA-BOARD INPUTS - 6A1	DISEGNATORE	N. DIS. DS610A.DWG	FOGLIO 8	SEGUE 9
			INTERNATIONAL STEEL CO s.p.a. Riese Pio x (TV)	SCHEMA DS610A	RIF. CLIENTE	DATA 04/01/2008	TOT. FOGLI 32	
REV.	DATA	OGGETTO MODIFICA	FIRMA		FIRMA	SCALA 1:1 mm		

A
B
C
D
E
F
G
H
I
J
K
L

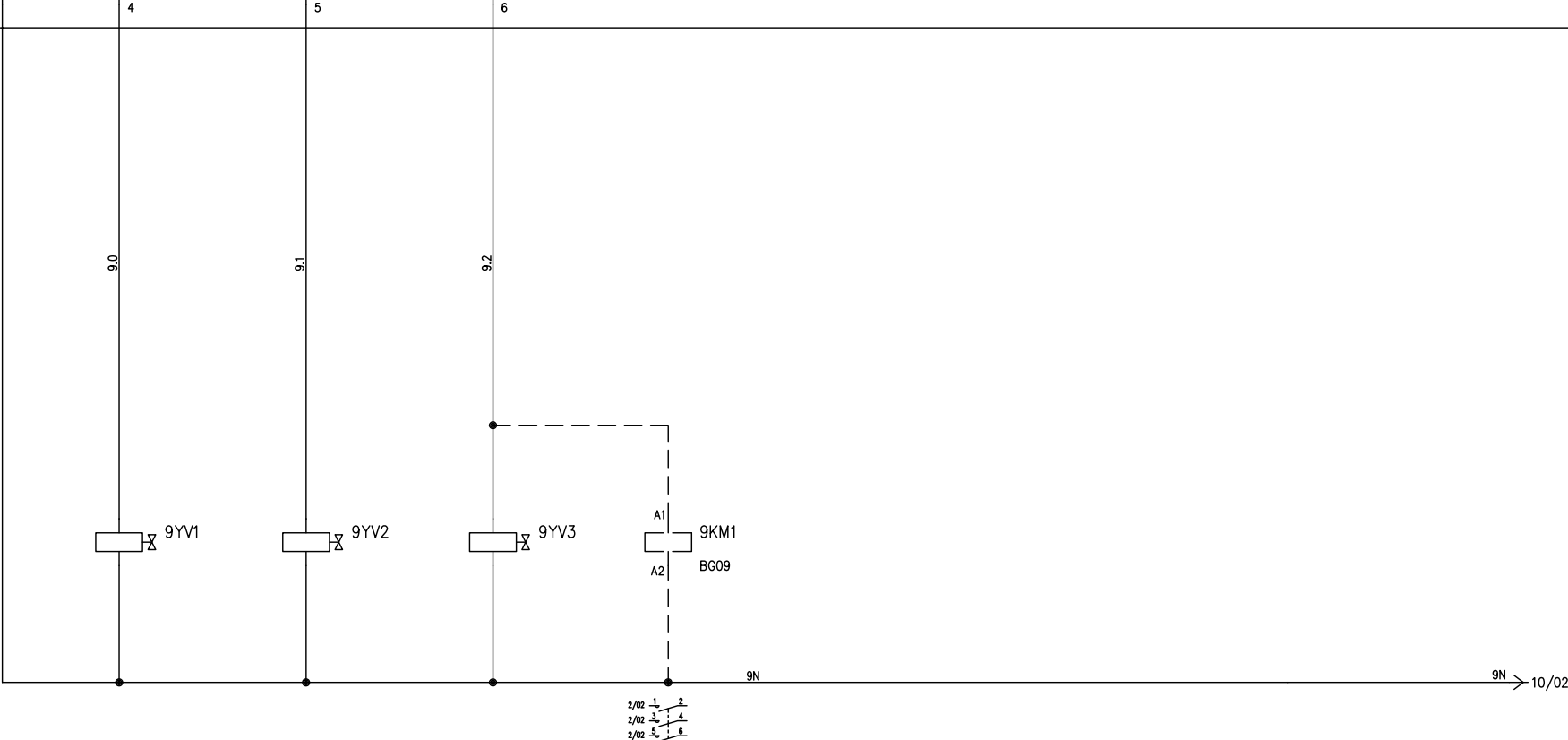
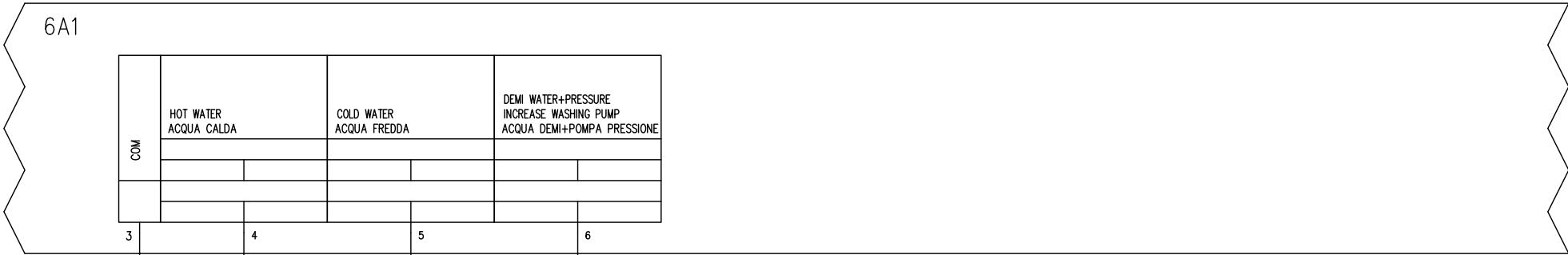

Fili disponibili da: 9.3
Wires available from: 9.3

			IMPIANTO LAVASTRUMENTI-WASHER DISINFECTOR DS610	TITOLO USCITE SCHEDA-BOARD OUTPUTS - 6A1	DISEGNATORE	N. DIS. DS610A.DWG N. ARCH.	FOGLIO 9	SEGUE 10	
REV.	DATA	OGGETTO MODIFICA	FIRMA	INTERNATIONAL STEEL CO s.p.a. Riese Pio x (TV)	SCHEMA DS610A	RIF. CLIENTE	FIRMA	DATA 04/01/2008	TOT. FOGLI
								SCALA 1:1 mm	32

IDEA R. 2007

6A1		TANK 1 AND 2 HEATING ELEMENT RESISTENZA VASCA 1 E 2	DEPURATION WATER ACQUA DEPURAZIONE	THANK STEAM SV EV VAPORE VASCA	DRAIN SV EV SCARICO VASCA	ALKALINE DOSING PUMP DOSATORE ALCALINO

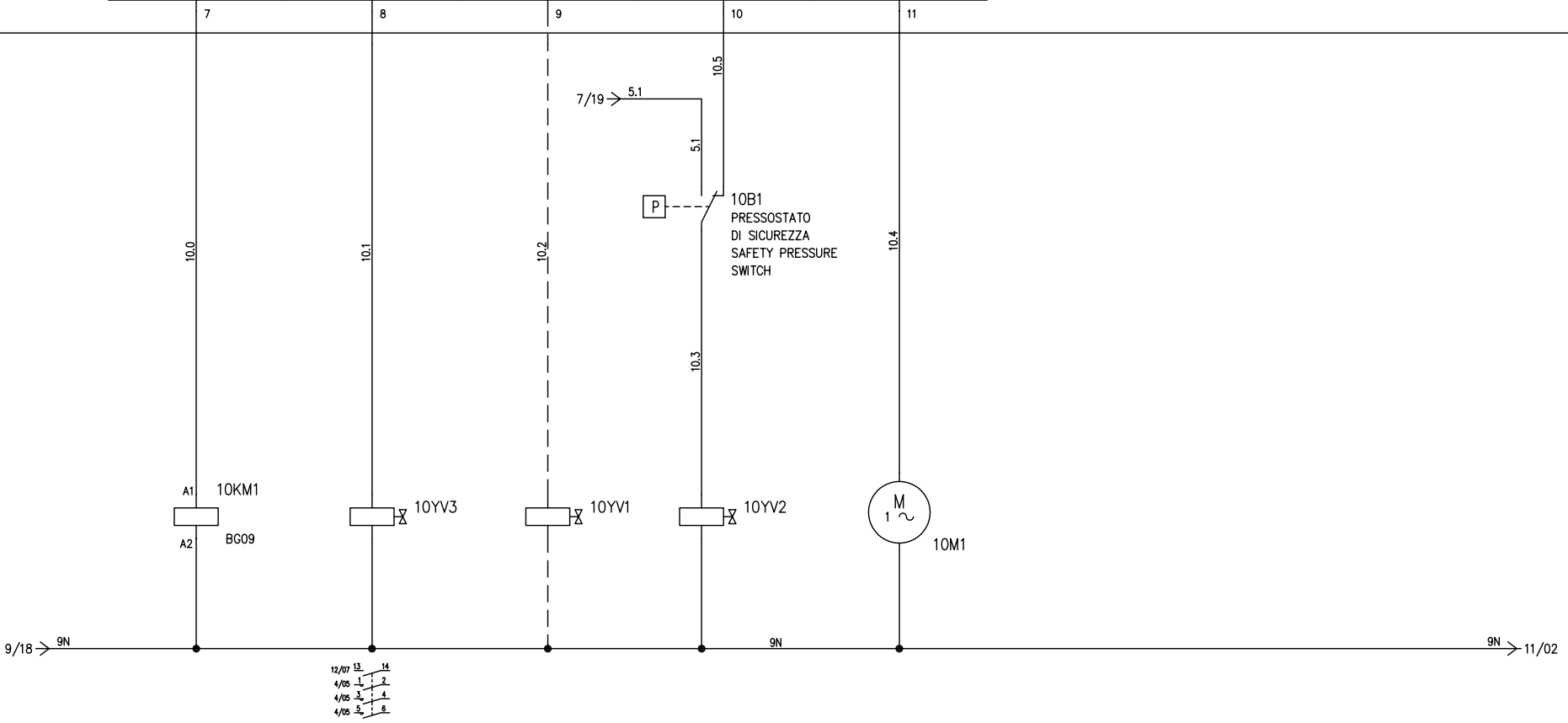

Fili disponibili dal: 10.6
Wires available from: 10.6

			IMPIANTO LAVASTRUMENTI-WASHER DISINFECTOR DS610	TITOLO USCITE SCHEDA-BOARD OUTPUTS - 6A1	DISEGNATORE	N. DIS. DS610A.DWG N. ARCH.	FOGLIO 10	SEGUE 11
REV.	DATA	OGGETTO MODIFICA	FIRMA	INTERNATIONAL STEEL CO s.p.a. Riese Pio x (TV)	SCHEMA DS610A	RIF. CLIENTE	FIRMA	TOT. FOGLI 32
						DATA 04/01/2008	SCALA 1:1 mm	

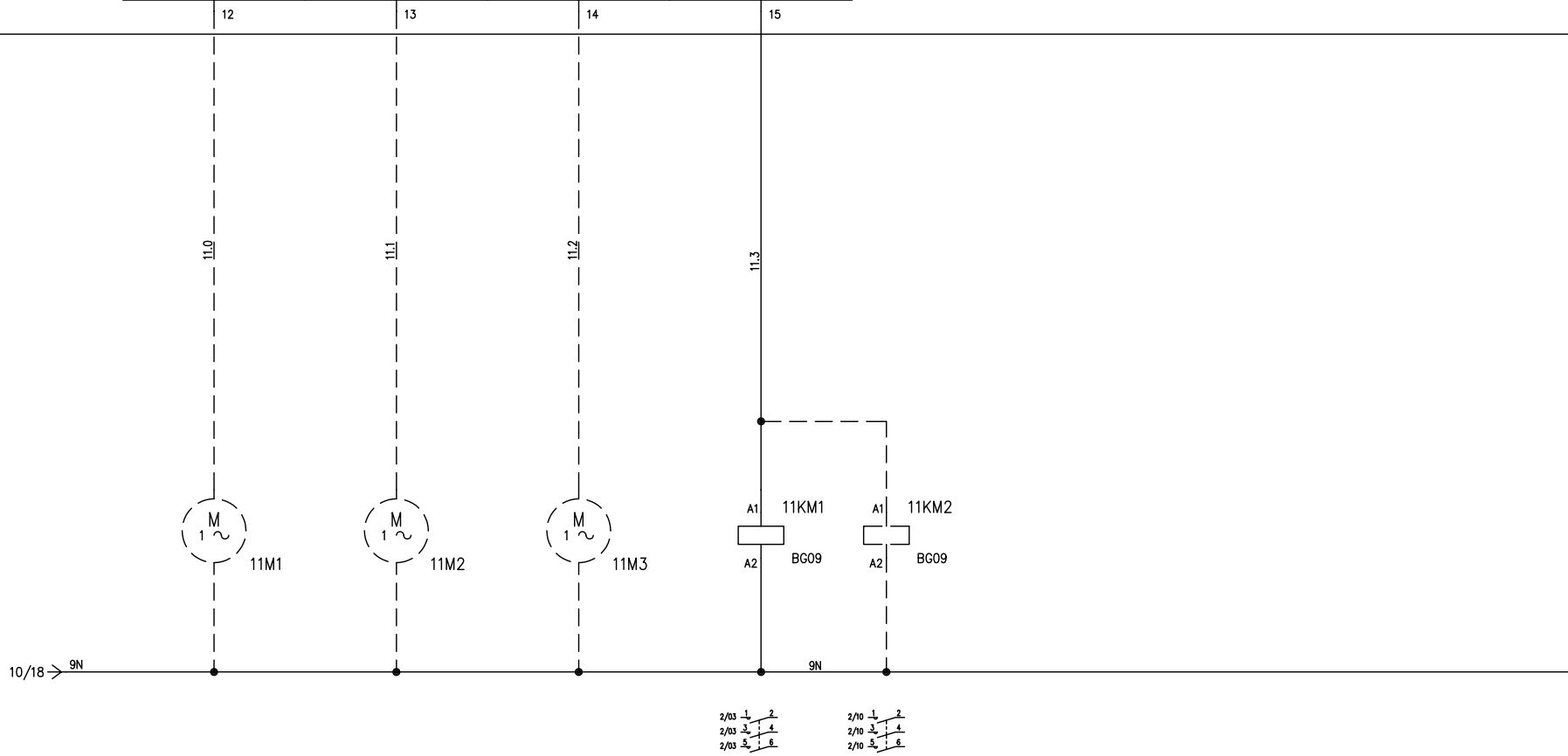
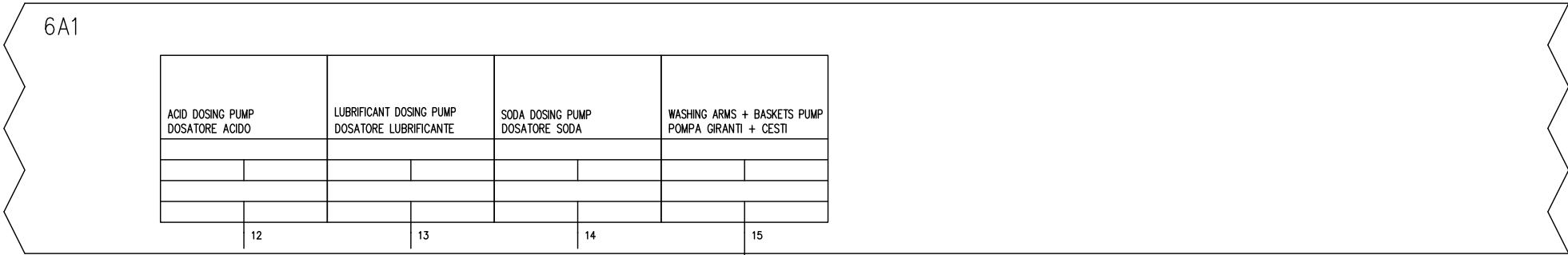

Fili disponibili dal: 11.4
Wires available from: 11.4

			IMPIANTO LAVASTRUMENTI-WASHER DISINFECTOR DS610	TITOLO USCITE SCHEDA-BOARD OUTPUTS - 6A1	DISEGNATORE	N. DIS. DS610A.DWG	FOGLIO 11	SEGUE 12
			INTERNATIONAL STEEL CO s.p.a. Riese Pio x (TV)	SCHEMA DS610A	RIF. CLIENTE	FIRMA	DATA 04/01/2008	TOT. FOGLI 32
REV.	DATA	OGGETTO MODIFICA	FIRMA			SCALA 1:1 mm		

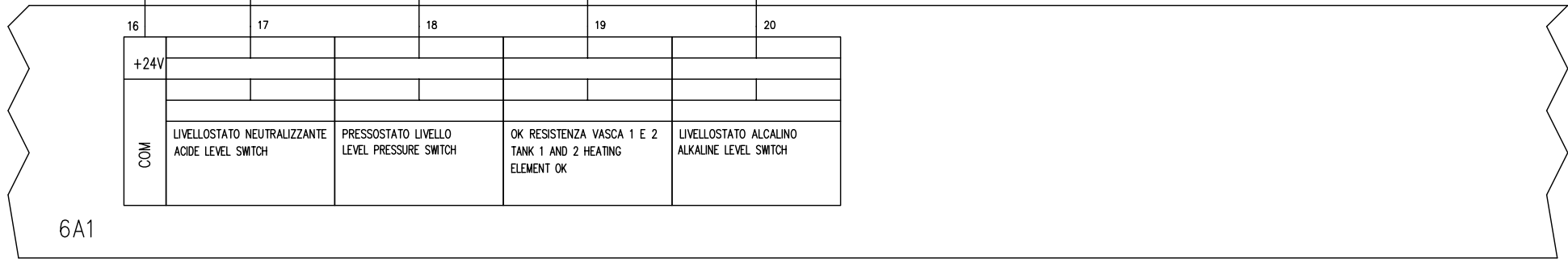
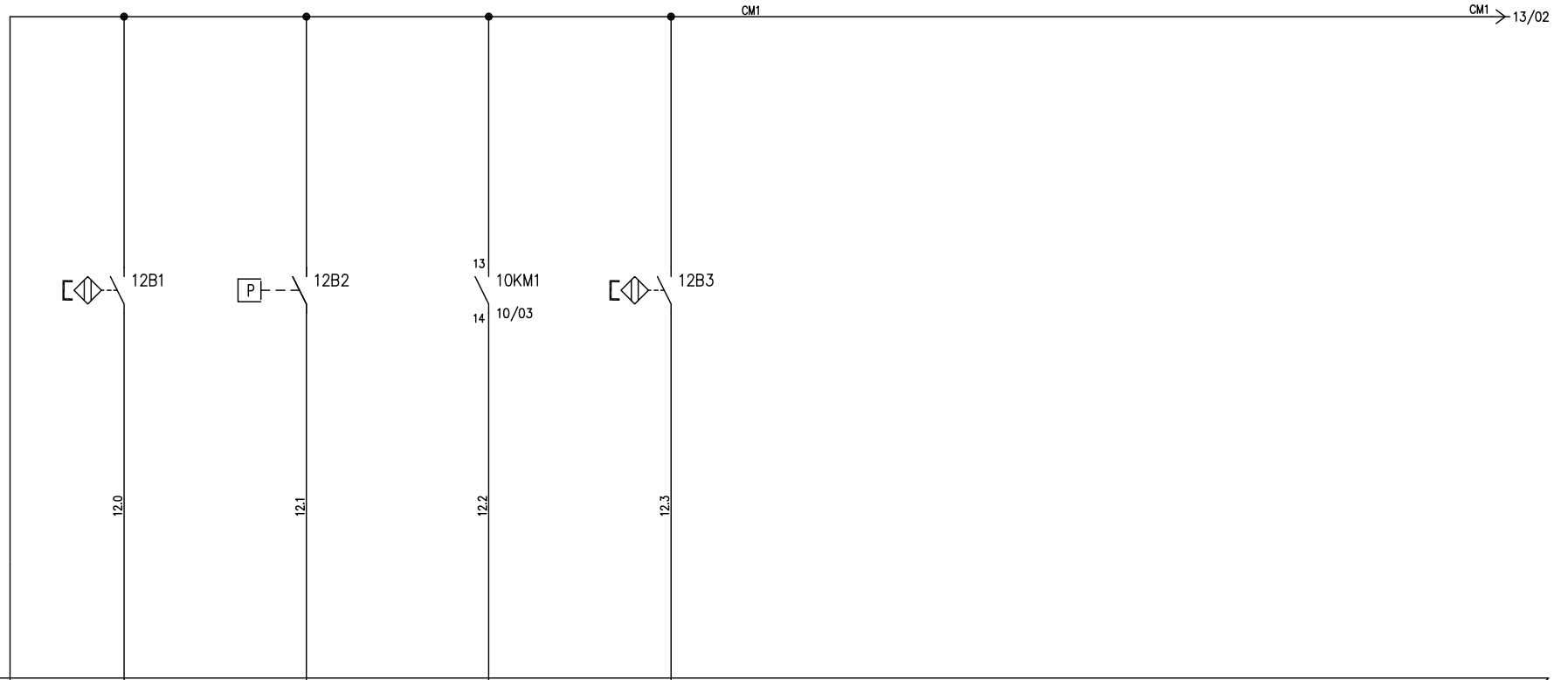

Fili disponibili dal: 12.4
Wires available from: 12.4

		IMPIANTO LAVASTRUMENTI-WASHER DISINFECTOR DS610		TITOLO INGRESSI SCHEDA-BOARD INPUTS - 6A1		DISEGNATORE		N. DIS. DS610A.DWG		FOGLIO 12		SEGUE 13	
		INTERNATIONAL STEEL CO s.p.a.		SCHEMA DS610A		RIF. CLIENTE		FIRMA		DATA 04/01/2008		TOT. FOGLI 32	
REV.	DATA	OGGETTO MODIFICA		FIRMA	Riese Pio x (TV)				SCALA 1:1 mm				

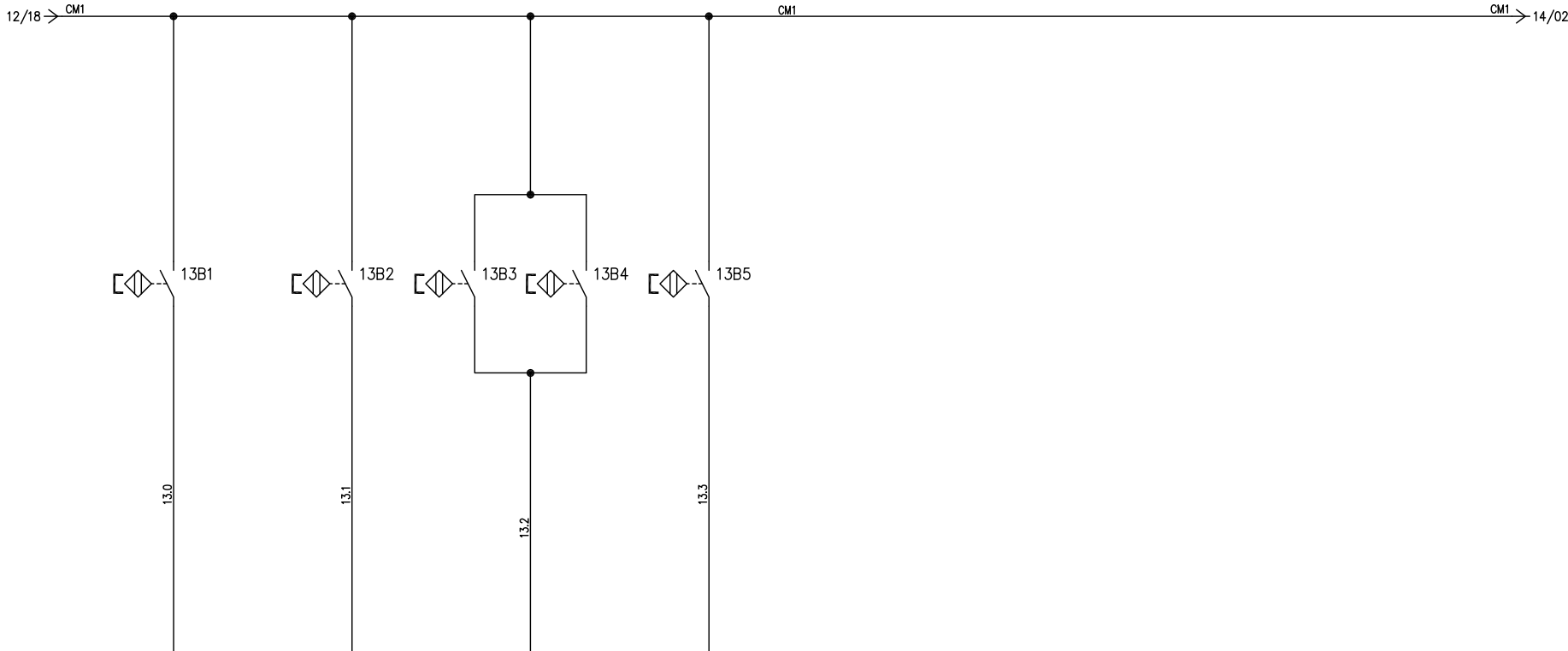

	21	22	23	24
	LIVELLOSTATO LUBRIFICANTE LUBRIFICANT LEVEL SWITCH	PORTA CARICO CHIUSA LOADING DOOR CLOSED	PRESENZA CESTO BASKET PRESENT	LIVELLOSTATO SODA SODA LEVEL SWITCH

6A1

Fili disponibili dal: 13.4
Wires available from: 13.4

				IMPIANTO LAVASTRUMENTI-WASHER DISINFECTOR DS610	TITOLO INGRESSI SCHEDA-BOARD INPUTS - 6A1	DISEGNATORE	N. DIS. DS610A.DWG	FOGLIO 13	SEGUE 14
				INTERNATIONAL STEEL CO s.p.a.	SHEMA DS610A	RIF. CLIENTE	FIRMA	DATA 04/01/2008	TOT. FOGLI 32
REV.	DATA	OGGETTO MODIFICA	FIRMA	Riese Pio x (TV)			SCALA 1:1 mm		

IDEA R. 2007

13/18 → CM1 CM1 CM1 → 15/02

14B1 14B2 14B3

14.0 14.1 14.2

25 26 27

BLOCCO PORTA CARICO APERTA/CHIUSA LOADING DOOR LOCK OPEN/CLOSE	BLOCCO PORTA SCARICO APERTA/CHIUSA UNLOADING DOOR LOCK OPEN/CLOSE	PORTA SCARICO CHIUSA UNLOADING DOOR CLOSED

6A1

Fili disponibili dal: 14.3
Wires available from: 14.3

			IMPIANTO LAVASTRUMENTI-WASHER DISINFECTOR DS610	TITOLO INGRESSI SCHEDA-BOARD INPUTS - 6A1	DISEGNATORE	N. DIS. DS610A.DWG	FOGLIO 14	SEGUE 15
			INTERNATIONAL STEEL CO s.p.a. Riese Pio x (TV)	SCHEMA DS610A	RIF. CLIENTE	FIRMA	DATA 04/01/2008	TOT. FOGLI 32
REV.	DATA	OGGETTO MODIFICA	FIRMA			SCALA 1:1 mm		

IDEA R. 2007

A
B
C
D
E
F
G
H
I
J
K
L

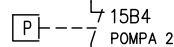
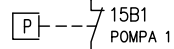

15.3

15.0

15.1

15.2

40

41

42

43

PRESSOSTATO POMPE LAVAGGIO PRESSURE SWITCH WASHING PUMPS	LIBERO FREE	LIBERO FREE	

6A1

Fili disponibili dal: 15.4
Wires available from: 15.4

			IMPIANTO LAVASTRUMENTI-WASHER DISINFECTOR DS610	TITOLO INGRESSI SCHEDA-BOARD INPUTS - 6A1	DISEGNATORE	N. DIS. DS610A.DWG	FOGLIO 15	SEGUE 16
			INTERNATIONAL STEEL CO s.p.a. Riese Pio x (TV)	SCHEMA DS610A	RIF. CLIENTE	FIRMA	DATA 04/01/2008	TOT. FOGLI 32
REV.	DATA	OGGETTO MODIFICA	FIRMA			SCALA 1:1 mm		

IDEA R. 2007

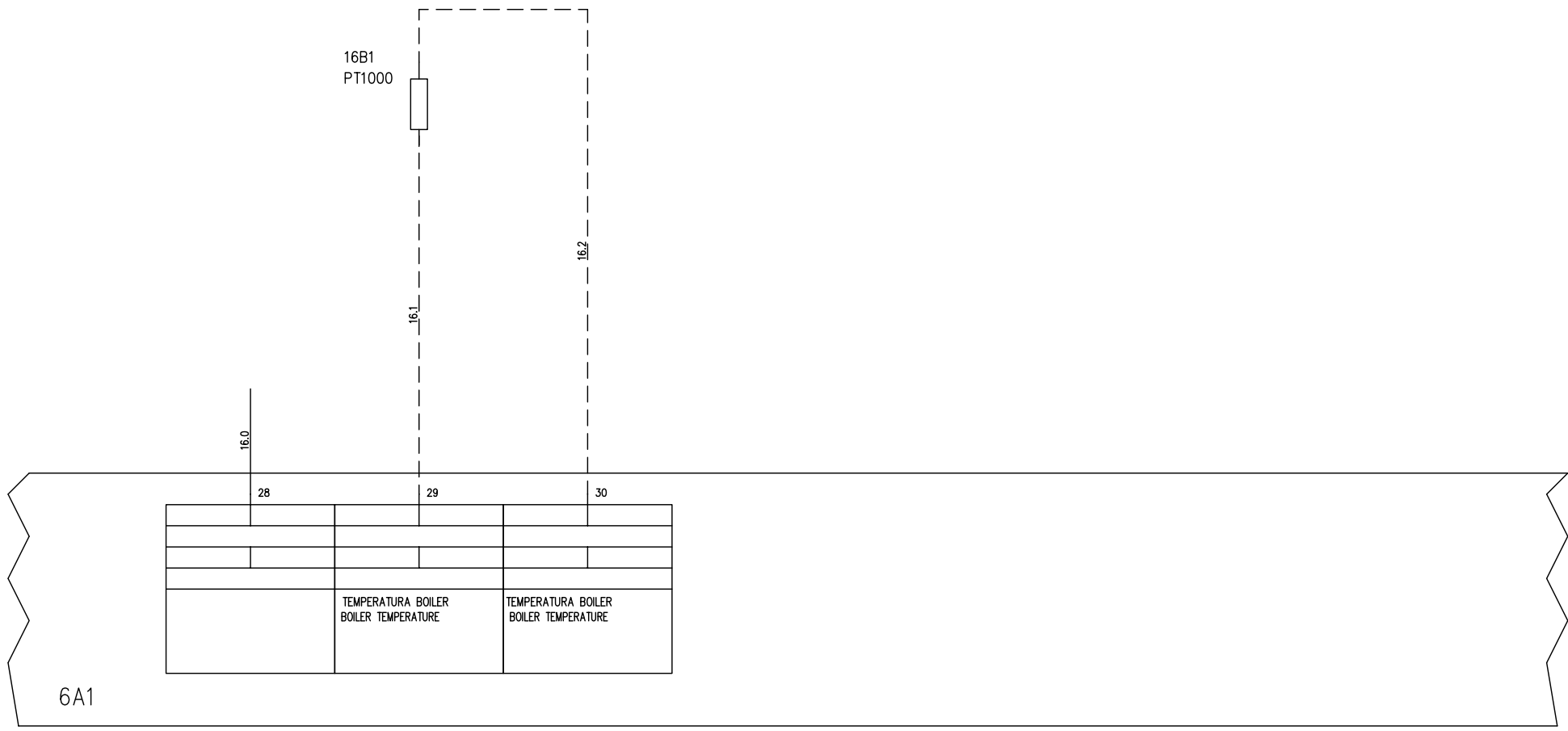

Fili disponibili dal: 16.3
Wires available from: 16.3

			IMPIANTO	TITOLO	DISEGNATORE	N. DIS.	FOGLIO	SEGUE
			LAVASTRUMENTI-WASHER DISINFECTOR DS610	INGRESSI SCHEDA-BOARD INPUTS - 6A1		DS610A.DWG	16	17
			INTERNATIONAL STEEL CO s.p.a.	SCHEMA	RIF. CLIENTE	DATA	TOT. FOGLI	
REV.	DATA	OGGETTO MODIFICA	FIRMA	DS610A		04/01/2008	32	
						SCALA		
						1:1 mm		

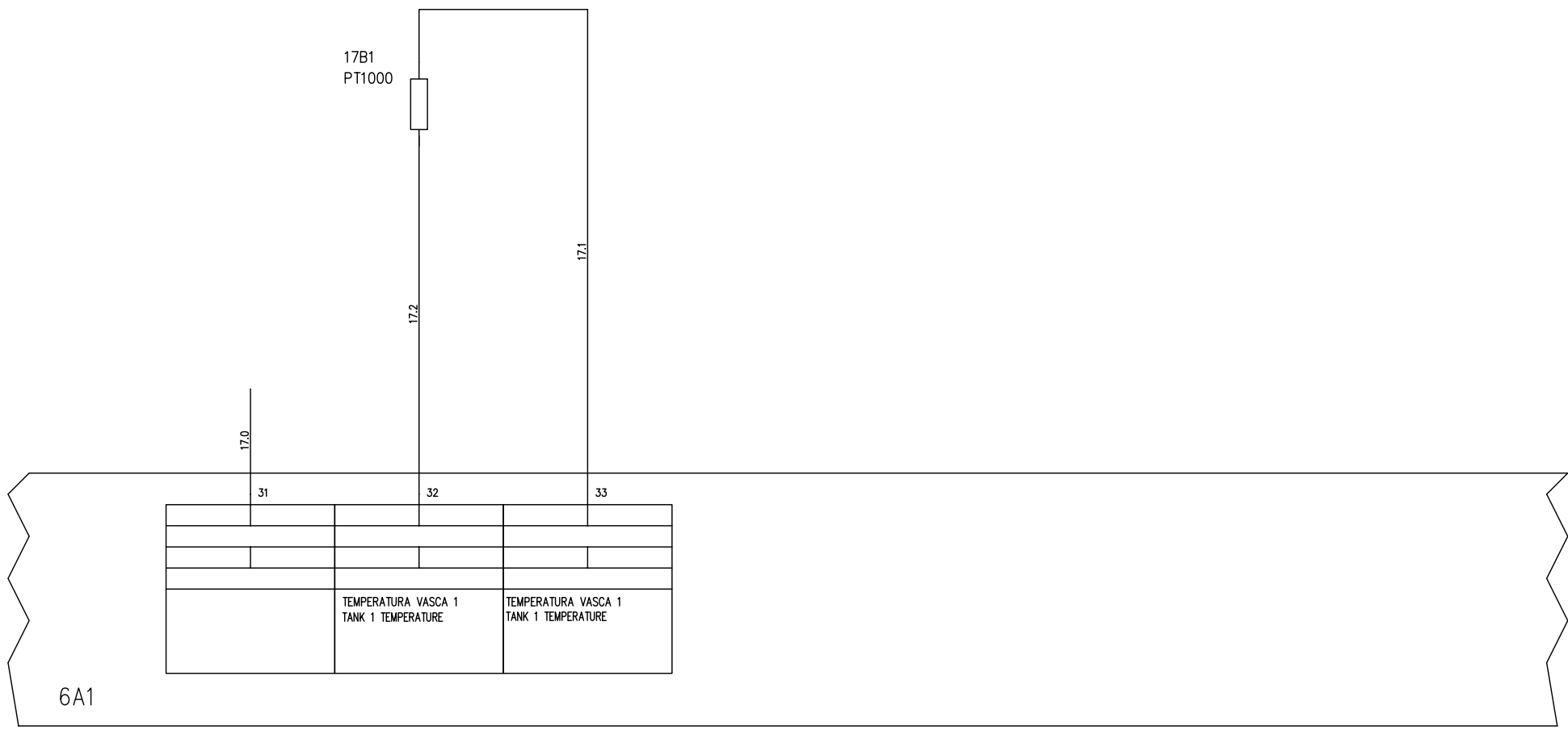

Fili disponibili dal: 17.3
Wires available from: 17.3

			IMPIANTO LAVASTRUMENTI-WASHER DISINFECTOR DS610	TITOLO INGRESSI SCHEDA-BOARD INPUTS - 6A1	DISEGNATORE	N. DIS. DS610A.DWG	FOGLIO 17	SEGUE 18
			INTERNATIONAL STEEL CO s.p.a. Riese Pio x (TV)	SCHEMA DS610A	RIF. CLIENTE	DATA 04/01/2008	TOT. FOGLI 32	
REV.	DATA	OGGETTO MODIFICA	FIRMA		FIRMA	SCALA 1:1 mm		

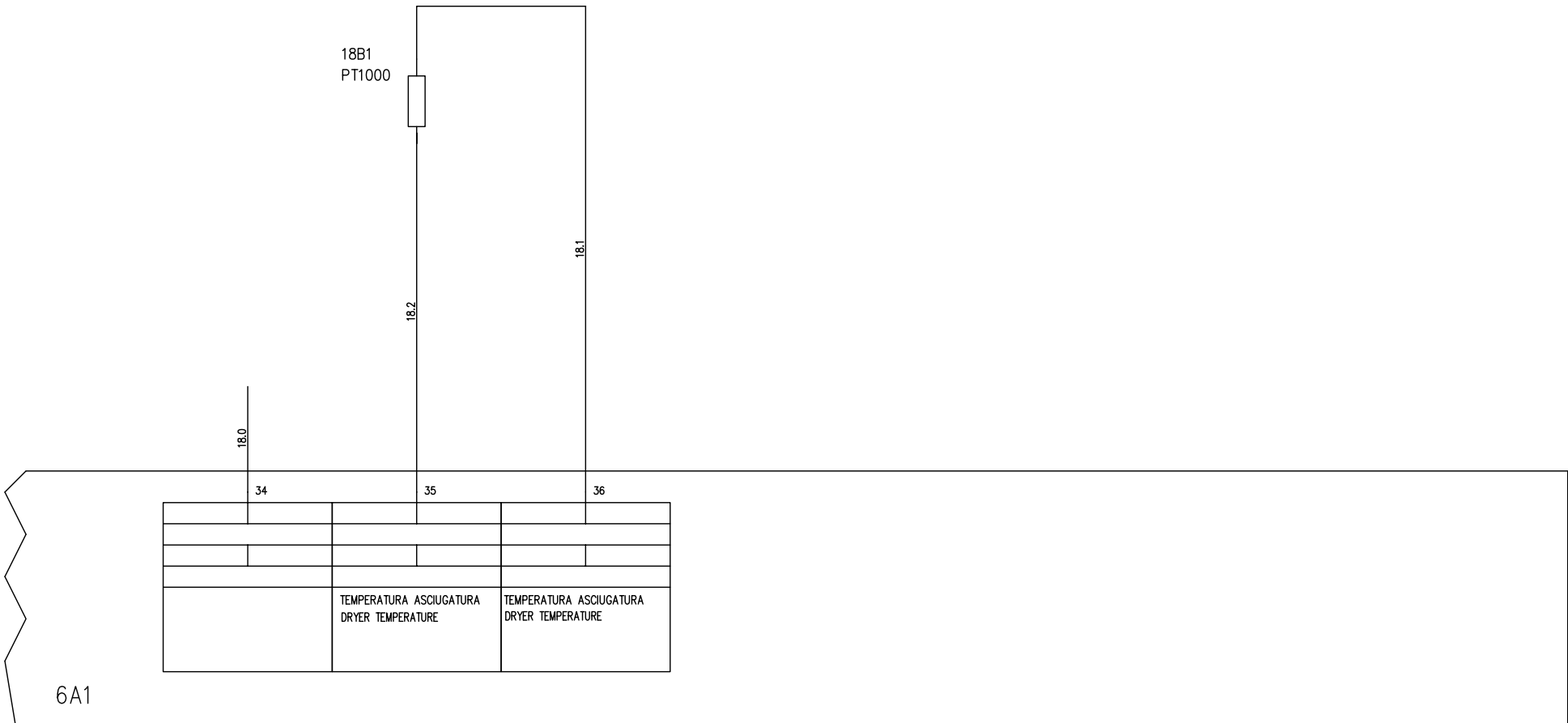

Fili disponibili dal: 18.3
Wires available from: 18.3

			IMPIANTO	TITOLO	DISEGNATORE	N. DIS.	FOGLIO	SEGUE
			LAVASTRUMENTI-WASHER DISINFECTOR DS610	INGRESSI SCHEDA-BOARD INPUTS - 6A1		DS610A.DWG	18	19
			INTERNATIONAL STEEL CO s.p.a.	SCHEMA	RIF. CLIENTE	DATA	TOT. FOGLI	
REV.	DATA	OGGETTO MODIFICA	FIRMA	DS610A		04/01/2008	32	
			Riese Pio x (TV)		FIRMA	SCALA		
						1:1 mm		

00 01 02 03 04 05 06 07 08 09 10 11 12 13 14 15 16 17 18 19

A
B
C
D
E
F
G
H
I
J
K
L

				IMPIANTO	LAVASTRUMENTI-WASHER DISINFECTOR DS610	TITOLO	LIBERA	DISEGNATORE		N. DIS.	DS610A.DWG	FOGLIO	19	SEGUE	20
										N. ARCH.					
										DATA	04/01/2008	TOT. FOGLI	32		
REV.	DATA		OGGETTO MODIFICA	FIRMA	INTERNATIONAL STEEL CO s.p.a. Riese Pio x (TV)	SCHEMA	DS610A	RIF. CLIENTE	FIRMA	SCALA	1:1 mm				

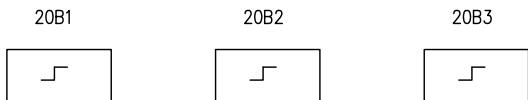

6A2

J1	J2	J3	J4	J5	J6	J7
FLUSSOMETRO ACQUA FREDDA COLD WATER FLOWMETER	FLUSSOMETRO ACQUA CALDA HOT WATER FLOWMETER	FLUSS. ACQUA DEMINERALIZZATA DEMI WATER FLOWMETER	LIBERO FREE	LIBERO FREE	LIBERO FREE	LIBERO FREE

			IMPIANTO LAVASTRUMENTI-WASHER DISINFECTOR DS610	TITOLO INGRESSI SCHEDA-BOARD INPUTS - 6A2	DISEGNATORE	N. DIS. DS610A.DWG	FOGLIO 20	SEGUE 21
			INTERNATIONAL STEEL CO s.p.a. Riese Pio x (TV)	SCHEMA DS610A	RIF. CLIENTE	DATA 04/01/2008	TOT. FOGLI 32	
REV.	DATA	OGGETTO MODIFICA	FIRMA		FIRMA	SCALA 1:1 mm		

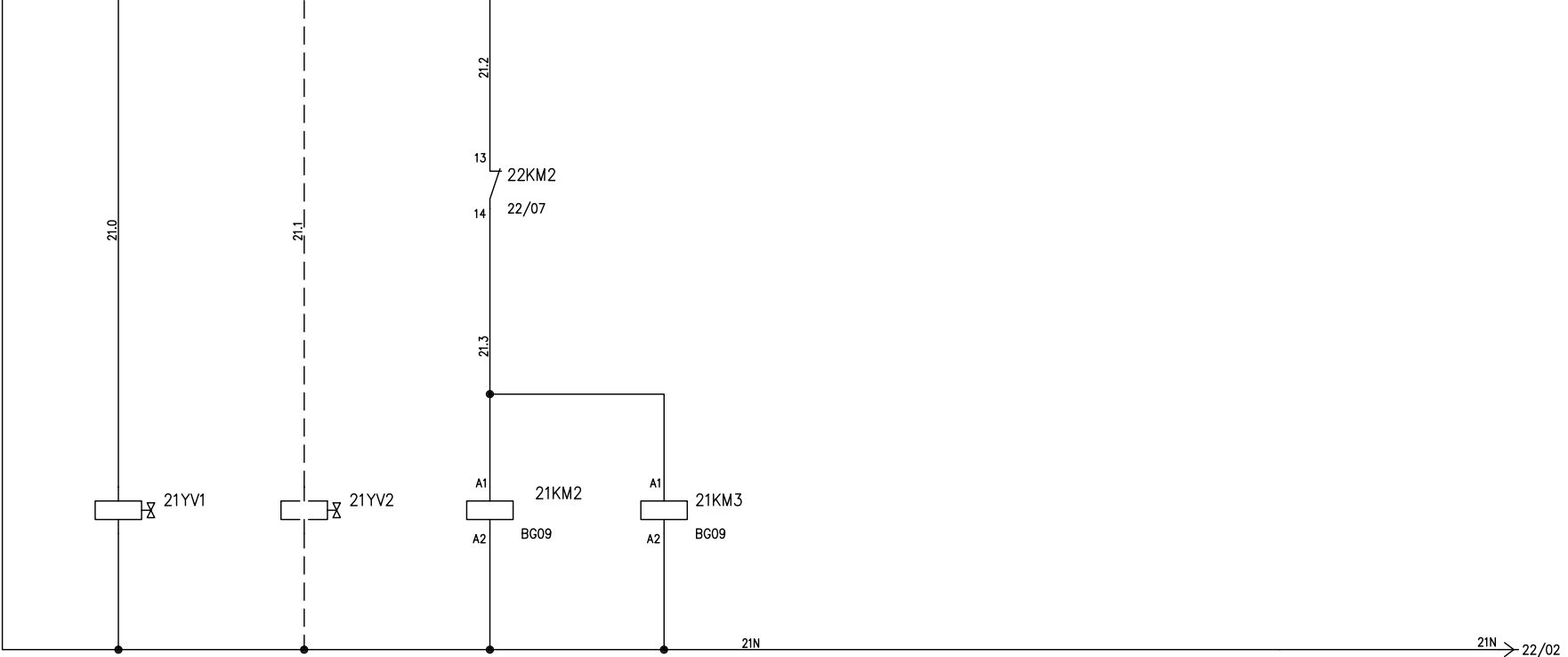
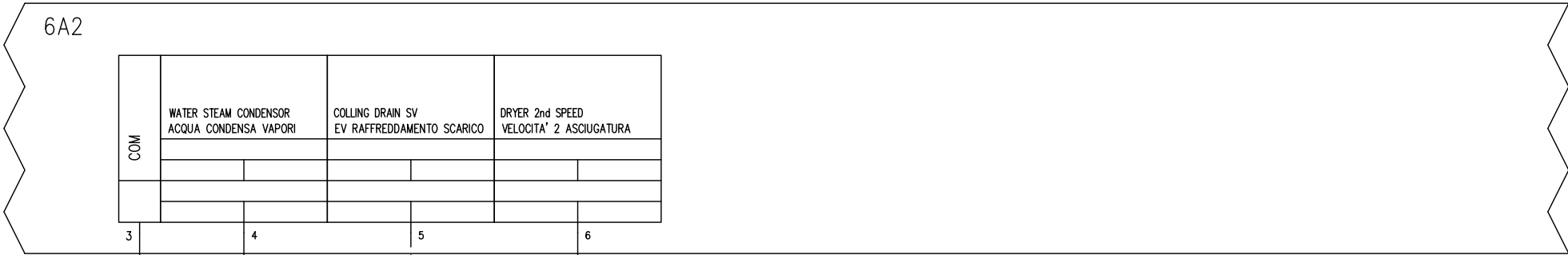

22/07	13	14
3/05	1	2
3/05	3	4
3/05	5	6

22/07	13	14
3/07	1	2
3/07	3	4
3/07	5	6

Fili disponibili dal: 21.4
Wires available from: 21.4

				IMPIANTO LAVASTRUMENTI-WASHER DISINFECTOR DS610	TITOLO USCITE SCHEDA-BOARD OUTPUTS - 6A2			N. DIS. DS610A.DWG	FOGLIO 21	SEGUE 22
				INTERNATIONAL STEEL CO s.p.a.				DATA 04/01/2008	TOT. FOGLI 32	
REV.	DATA	OGGETTO MODIFICA	FIRMA	Riese Pio x (TV)	SCHEMA DS610A	RIF. CLIENTE	FIRMA	SCALA 1:1 mm		

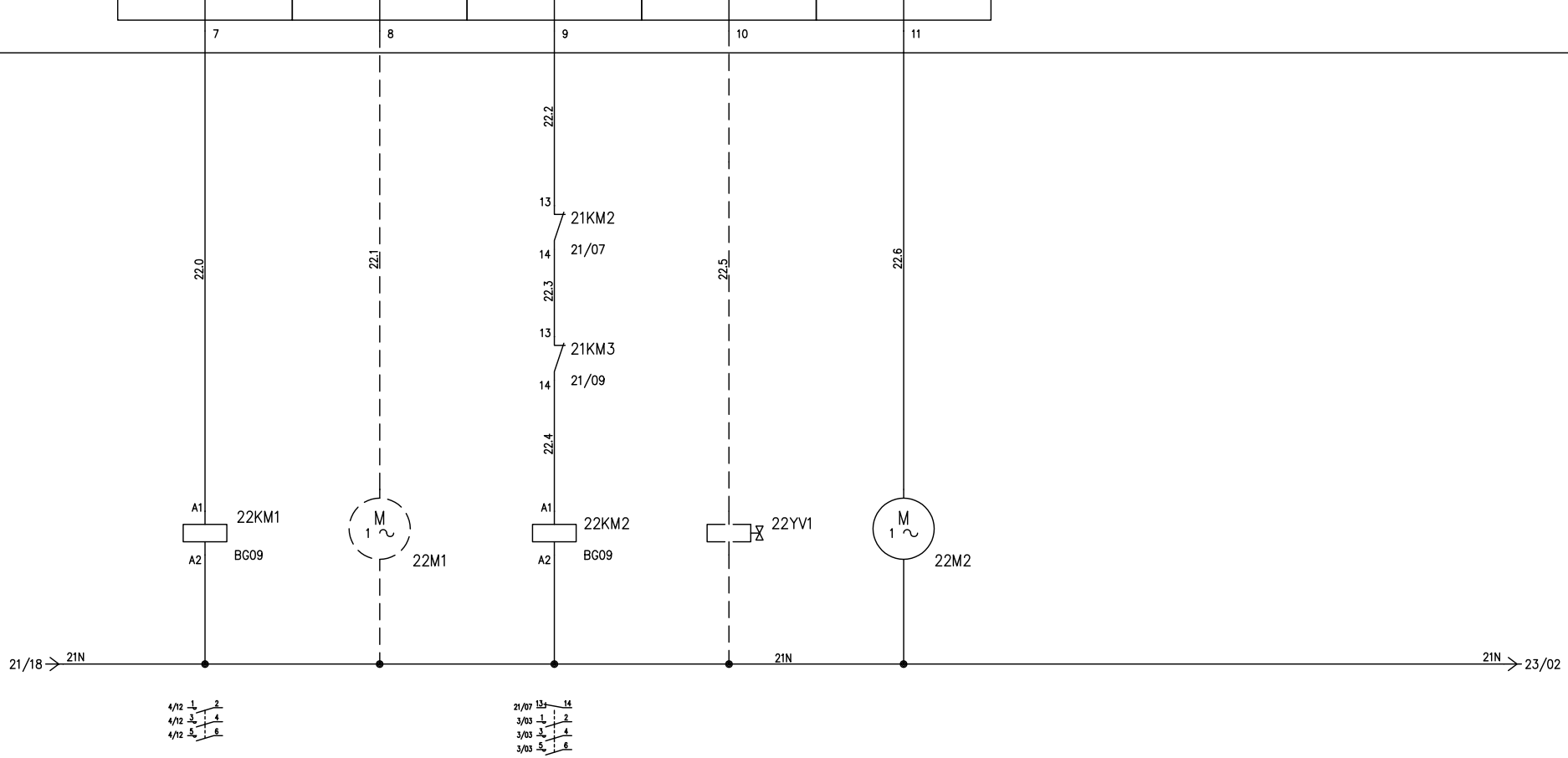
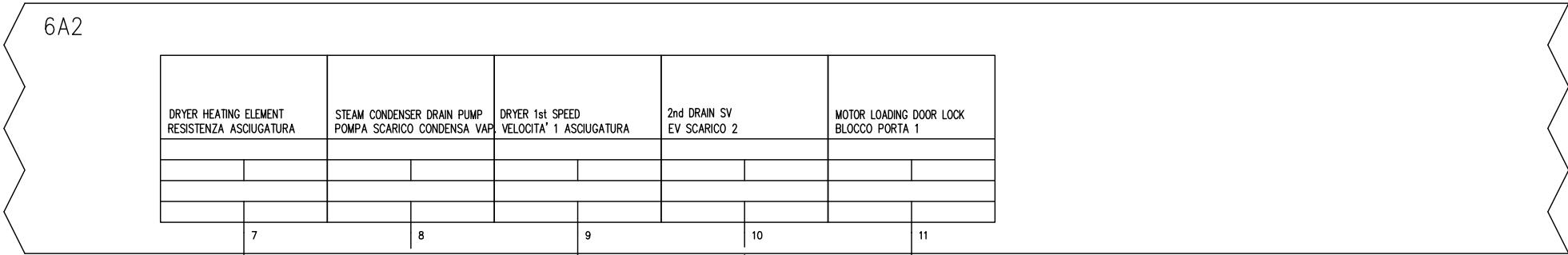

Fili disponibili dal: 22.7
Wires available from: 22.7

			IMPIANTO LAVASTRUMENTI-WASHER DISINFECTOR DS610	TITOLO USCITE SCHEDA-BOARD OUTPUTS - 6A2	DISEGNATORE	N. DIS. DS610A.DWG	FOGLIO 22	SEGUE 23
			INTERNATIONAL STEEL CO s.p.a. Riese Pio x (TV)	SCHEMA DS610A	RIF. CLIENTE	FIRMA	TOT. FOGLI 32	
REV.	DATA	OGGETTO MODIFICA	FIRMA			DATA 04/01/2008	SCALA 1:1 mm	

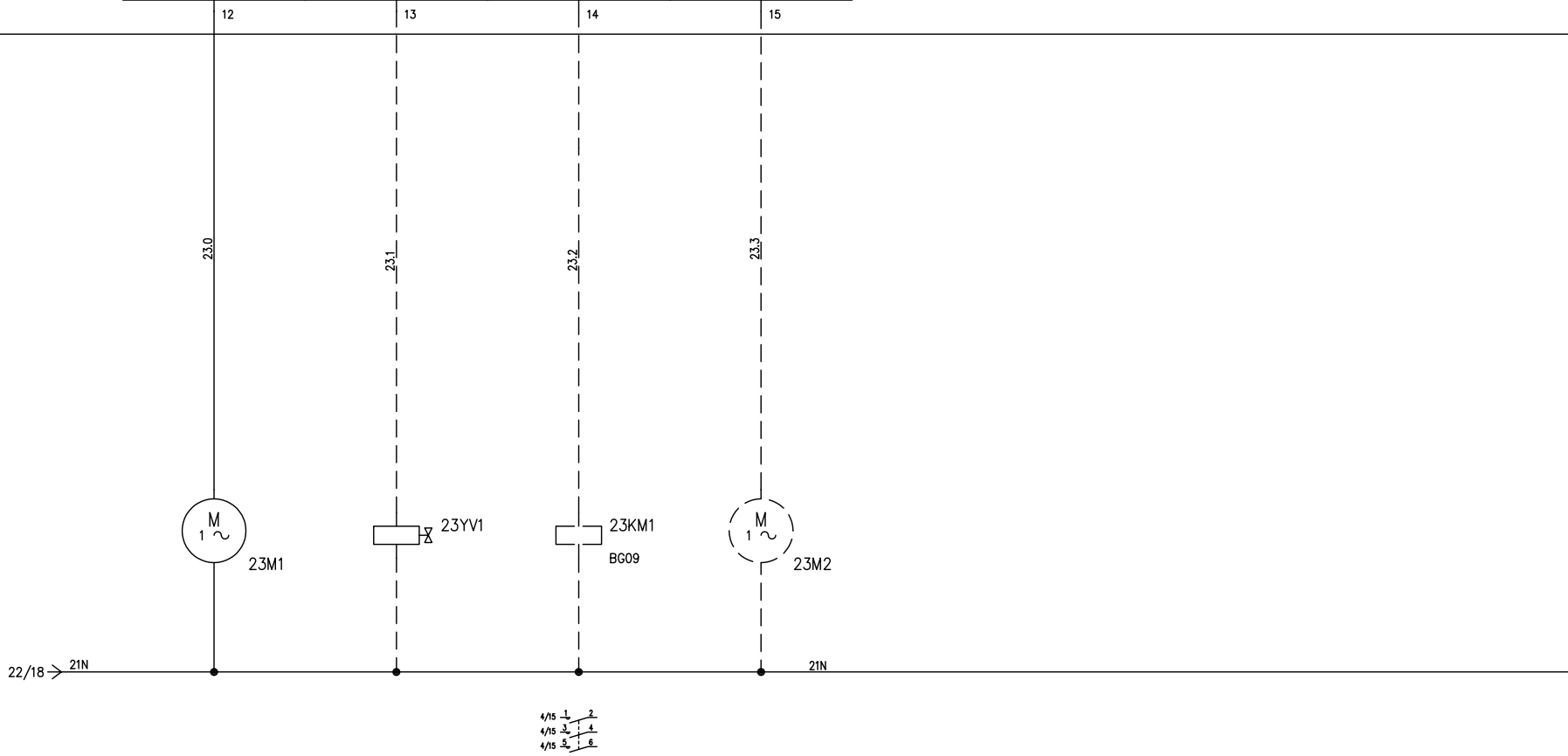
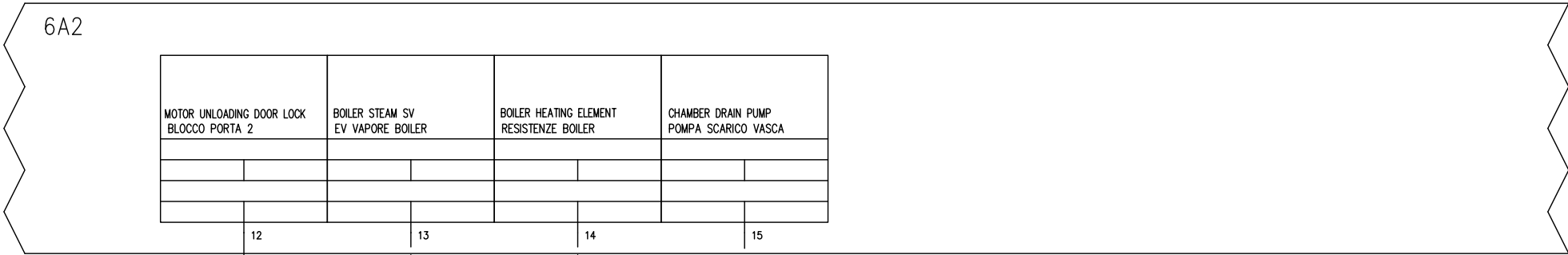

Fili disponibili dal: 23.4
Wires available from: 23.4

			IMPIANTO LAVASTRUMENTI-WASHER DISINFECTOR DS610	TITOLO USCITE SCHEDA-BOARD OUTPUTS - 6A2	DISEGNATORE	N. DIS. DS610A.DWG	FOGLIO 23	SEGUE 24
			INTERNATIONAL STEEL CO s.p.a. Riese Pio x (TV)	SCHEMA DS610A	RIF. CLIENTE	FIRMA	DATA 04/01/2008	TOT. FOGLI 32
REV.	DATA	OGGETTO MODIFICA	FIRMA			SCALA 1:1 mm		

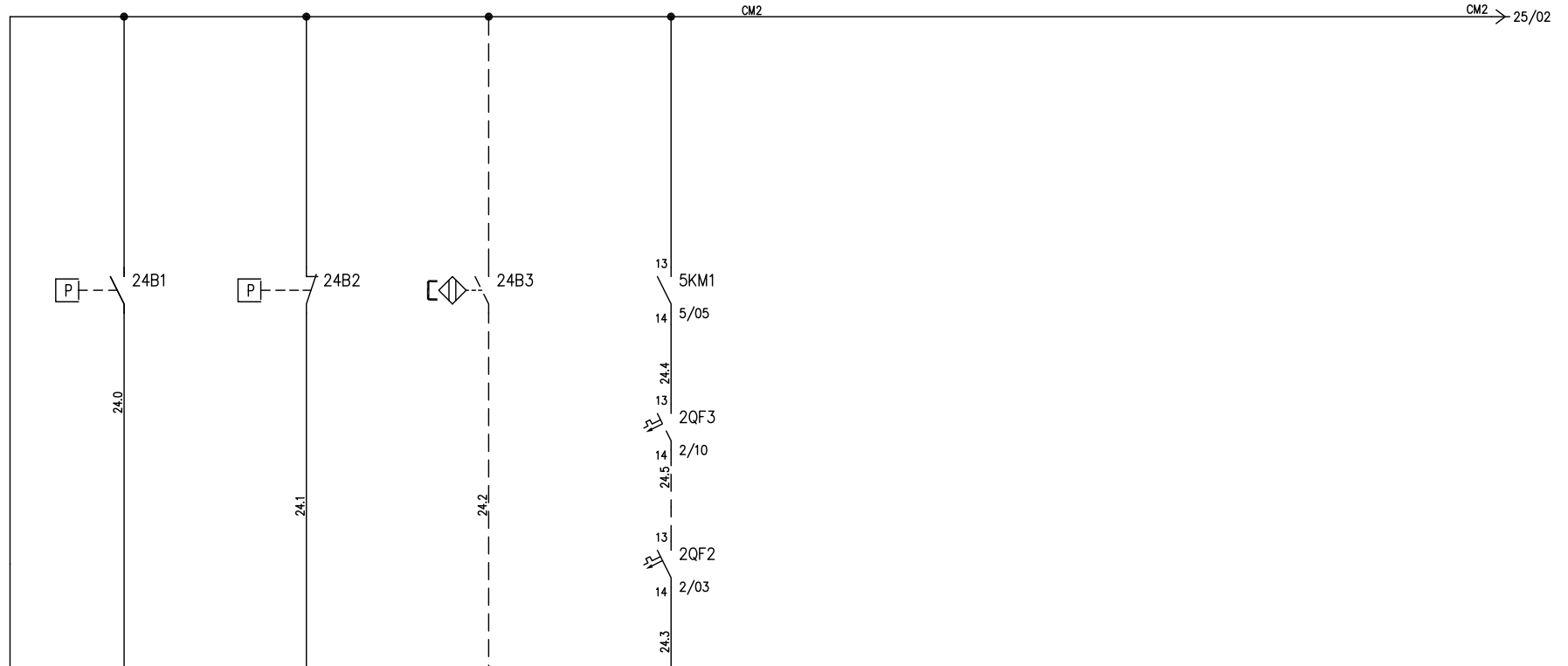

16	17	18	19	20
+24V				
COM	PRESSOSTATO ASCIUGATURA DRYER PRESSURE SWITCH	DEPRESSOSTATO FILTRI H EPA HEPA FILTERS DREPRESSURE SWITCH	LIVELLO CONDENSA STEAM CONDENSER LEVEL	ALLARME SICUREZZE SAFETY ALARM

6A2

Fili disponibili dal: 24.6
Wires available from: 24.6

IMPIANTO LAVASTRUMENTI-WASHER DISINFECTOR DS610			TITOLO INGRESSI SCHEDA-BOARD INPUTS - 6A2		DISEGNATORE		N. DIS. DS610A.DWG		FOGLIO 24		SEGUE 25
INTERNATIONAL STEEL CO s.p.a. Riese Pio x (TV)			SCHEMA DS610A		RIF. CLIENTE		FIRMA		DATA 04/01/2008		TOT. FOGLI 32
REV.	DATA	OGGETTO MODIFICA	FIRMA					SCALA 1:1 mm			

24/18 → CM2 CM2 CM2 → 26/02

15
18 16
1KA1
(EXT.)
1/06

25B1

25B2

25.0

25.1

25.2

21

22

23

24

SEQUENZA CORRETTA FASI CORRECT PHASES SEQUENCE	LIVELLO BOILER BOILER LEVEL SWITCH		LIVELLO SICUREZZA CONDENZA CONDENSATE SAFETY LEVEL

6A2

Fili disponibili dal: 25.3
Wires available from: 25.3

			IMPIANTO LAVASTRUMENTI-WASHER DISINFECTOR DS610	TITOLO INGRESSI SCHEDA-BOARD INPUTS - 6A2	DISEGNATORE	N. DIS. DS610A.DWG	FOGLIO 25	SEGUE 26
			INTERNATIONAL STEEL CO s.p.a. Riese Pio x (TV)	SCHEMA DS610A	RIF. CLIENTE	DATA 04/01/2008	TOT. FOGLI 32	
REV.	DATA	OGGETTO MODIFICA	FIRMA		FIRMA	SCALA 1:1 mm		

IDEA R. 2007

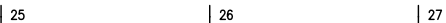
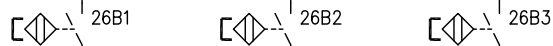
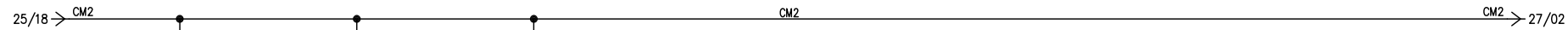

RICONOSCIMENTO CESTO 1 BASKET RICOGNITION 1	RICONOSCIMENTO CESTO 2 BASKET RICOGNITION 2	RICONOSCIMENTO CESTO 3 BASKET RICOGNITION 3

6A2

Fili disponibili dal: 26.3
Wires available from: 26.3

			IMPIANTO	TITOLO	DISEGNATORE	N. DIS.	FOGLIO	SEGUE
			LAVASTRUMENTI-WASHER DISINFECTOR DS610	INGRESSI SCHEDA-BOARD INPUTS - 6A2		DS610A.DWG	26	27
						N. ARCH.		
						DATA		
REV.	DATA	OGGETTO MODIFICA	FIRMA	SCHEMA	RIF. CLIENTE	FIRMA	TOT. FOGLI	
				DS610A			32	
						SCALA		
						1:1 mm		

INTERNATIONAL STEEL CO s.p.a.
Riese Pio x (TV)

IDEA R. 2007



40	41	42	43
RICONOSCIMENTO CESTO 4 BASKET RICOGNITION 4	RICONOSCIMENTO CESTO 5 BASKET RICOGNITION 5	LIBERO FREE	

6A2

Fili disponibili dal: 27.3
Wires available from: 27.3

			IMPIANTO LAVASTRUMENTI-WASHER DISINFECTOR DS610	TITOLO INGRESSI SCHEDA-BOARD INPUTS - 6A2	DISEGNATORE	N. DIS. DS610A.DWG	FOGLIO 27	SEGUE 28
			INTERNATIONAL STEEL CO s.p.a.	SCHEMA DS610A	RIF. CLIENTE	FIRMA	DATA 04/01/2008	TOT. FOGLI 32
REV.	DATA	OGGETTO MODIFICA	FIRMA	Riese Pio x (TV)		SCALA 1:1 mm		

IDEA R. 2007

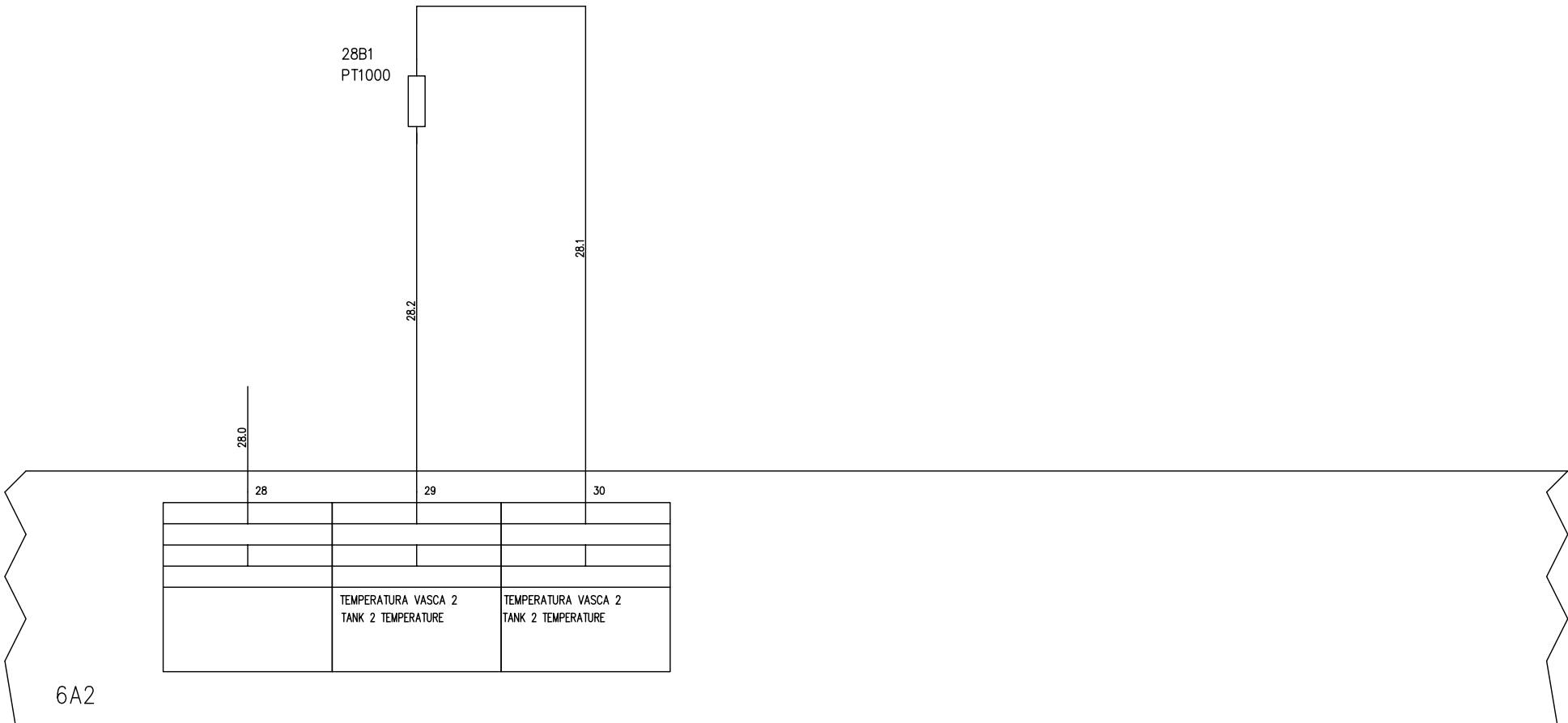

Fili disponibili dal: 28.3
Wires available from: 28.3

				IMPIANTO LAVASTRUMENTI-WASHER DISINFECTOR DS610	TITOLO INGRESSI SCHEDA-BOARD INPUTS - 6A2	DISEGNATORE	N. DIS. DS610A.DWG	FOGLIO 28	SEGUE 29
				INTERNATIONAL STEEL CO s.p.a. Riese Pio x (TV)	SCHEMA DS610A	RIF. CLIENTE	FIRMA	DATA 04/01/2008	TOT. FOGLI 32
REV.	DATA	OGGETTO MODIFICA	FIRMA				SCALA 1:1 mm		

A

B

C

D

E

F

G

H

I

J

K

L



Fili disponibili dal: 29.3
Wires available from: 29.3

			IMPIANTO	LAVASTRUMENTI-WASHER DISINFECTOR DS610	TITOLO	INGRESSI SCHEDA-BOARD INPUTS - 6A2	DISEGNATORE	N. DIS.	DS610A.DWG	FOGLIO	29	SEGUE	30
								N. ARCH.					
								DATA	04/01/2008	TOT. FOGLI	32		
REV.	DATA	OGGETTO MODIFICA	FIRMA	INTERNATIONAL STEEL CO s.p.a. Riese Pio x (TV)	SCHEMA	DS610A	RIF. CLIENTE	FIRMA	SCALA	1:1 mm			

IDEA R. 2007

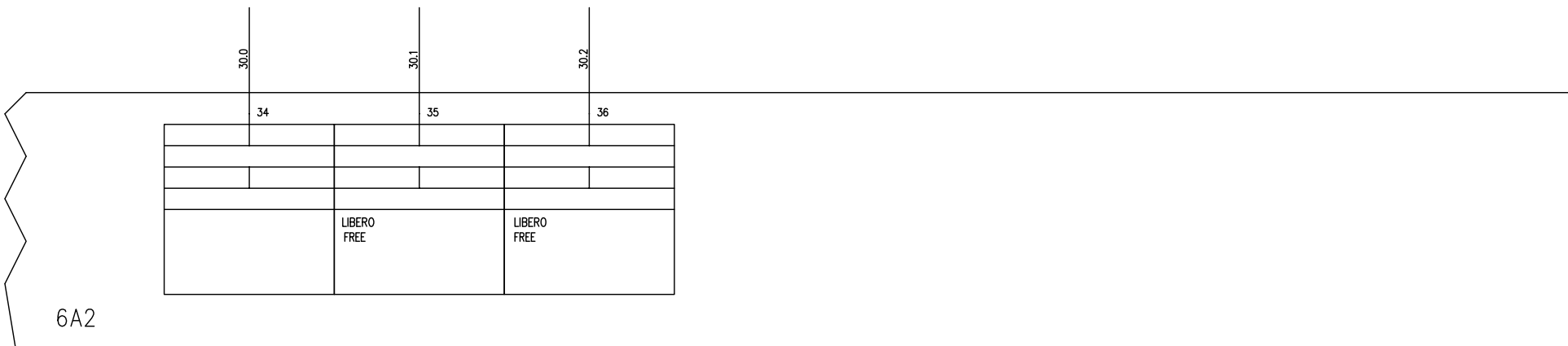

Fili disponibili dal: 30.3
Wires available from: 30.3

				IMPIANTO	TITOLO	DISEGNATORE	N. DIS.	FOGLIO	SEGUE
				LAVASTRUMENTI-WASHER DISINFECTOR DS610	INGRESSI SCHEDA-BOARD INPUTS - 6A2		DS610A.DWG	30	31
				INTERNATIONAL STEEL CO s.p.a.	SCHEMA	RIF. CLIENTE	DATA	TOT. FOGLI	
REV.	DATA	OGGETTO MODIFICA	FIRMA	Riese Pio x (TV)	DS610A		04/01/2008	32	
						FIRMA	SCALA		
							1:1 mm		

00 01 02 03 04 05 06 07 08 09 10 11 12 13 14 15 16 17 18 19

A
B
C
D
E
F
G
H
I
J
K
L

				IMPIANTO	LAVASTRUMENTI-WASHER DISINFECTOR DS610	TITOLO	LIBERO	DISEGNATORE		N. DIS.	DS610A.DWG	FOGLIO	31	SEGUE
										N. ARCH.				
										DATA	04/01/2008	TOT. FOGLI	32	
REV.	DATA		OGGETTO MODIFICA	FIRMA	INTERNATIONAL STEEL CO s.p.a. Riese Pio x (TV)	SCHEMA	DS610A	RIF. CLIENTE	FIRMA	SCALA	1:1 mm			