

Contents

Preface	4
Valid for	5
Important information	6
Safety instructions	6
Manufacturer's declaration	8
1. System description	9
Fundamental actuator construction	10
Warranty and service life	11
IP Protection degree	11
LINAK washing procedure for IPX6 Washable products	12
Cable Wash	13
Maintenance	14
Environmental conditions	14
Insulation class	15
Key to symbols	15
Mounting	17
Connecting the system	18
JUMBO system (special information)	19
2. information on start-up, de-installation and operation	21
Troubleshooting Actuators/Lifting columns	22
Troubleshooting Electronics	23
3. Information on specific actuators	24
4. Information on specific columns	37
5. Information on specific controls boxes	40
6. Information on specific controls	46
7. Information on specific JUMBO	50
8. Information on specific accessories	53
9. Repair and disposal	55
Main groups of disposal	56
Practical information	58
Drawings	60
Addresses	68

Preface

Dear User,

We are delighted that you have chosen a product from LINAK®.

LINAK systems are high-tech products based on many years of experience in the manufacture and development of actuators, electric control boxes, controls and chargers.

This User Manual will tell you how to install, use and maintain your LINAK electronics. We are sure that your LINAK system will give you many years of problem-free operation.

Before our products leave the factory they undergo full function and quality testing. Should you nevertheless experience problems with your systems, you are always welcome to contact your local dealer.

LINAK subsidiaries and some distributors situated all over the world have authorised service centres, which are always ready to help you.

LINAK provides a warranty on all its products.

This warranty, however, is subject to correct use in accordance with the specifications, maintenance being done correctly and any repairs being carried out at a service centre, which is authorised to repair LINAK products.

Changes in installation and use of LINAK systems can affect their operation and durability. The products are not to be opened by unauthorised personnel.

The User Manual has been written on the basis of our present technical knowledge. We are constantly working on updating the information and we therefore reserve the right to carry out technical modifications.

LINAK A/S

Valid for:

This User Manual is valid for the following products:

(See the first 3 - 5 characters on the label)

Actuators:	LA12, LA22, LA23, LA27, LA28, LA29, LA30, LA31, LA32, LA34, LA44
Columns:	BB3, BL1, BL4, LC2, LP2, LP3
Control boxes:	CB6, CB6S, CB7, CB8-A, CB8-T, CB9, CB12, CB14, CB16, CB20
Controls:	ACC, ACK, ACL, ACM, ACP, ACO, FPP, FS, FS2, HB20, HB40, HB50, HB60, HB70, HB80, HL70, HL80, IRO, LS/LSD
JUMBO systems:	BAJ1/2, CBJ1/2, CBJC, CBJH, CH01, CH08, CHJ2, MBJ1/2/3
Accessories:	BA18, CS16, DJB, MJB, SLS, COBO20

Important information

Description of the various signs used in this manual.



Warning!

Failure to comply with these instructions may result in accidents involving serious personal injury.



Failing to follow these instructions can result in the product being damaged or destroyed.

Safety instructions



Please read the following safety information carefully.

It is important for everyone who is to connect, install or use the systems to have the necessary information and access to this User Manual.

Please be advised that LINAK has taken precautions to ensure the safety of the actuator system. It is the responsibility of the manufacturer/OEM to get the overall approval for the complete application.

LINAK recommends that the actuators should be used in push applications, rather than pull applications.

If the actuator is used for push in an application where personal injury can occur (e.g. patient hoists), a special safety nut must be used.

Except for LA34 which can be used for both push or pull applications, if mounted with safety nuts in both directions.

Persons who do not have the necessary experience or knowledge of the product/products must not use the product/products. Besides, persons with reduced physical or mental abilities must not use the product/products, unless they are under surveillance or they have been thoroughly instructed in the use of the apparatus by a person who is responsible for the safety of these persons.

“Do not remain under the application during operation or operate the application when assembling/disassembling moving parts”.

Moreover, children must be under surveillance to ensure that they do not play with the product.

Classification:

The equipment is not suitable for use in the presence of a flammable anesthetic mixture with air or with oxygen or nitrous oxide.

Electromagnetic compatibility

LINAK Actuator Systems bear the CE marking as an attestation of compliance with the EMC Directive 2004/108/EC; the systems are designed to meet all requirements of applicable standards and have been tested to such requirements.

It is unlikely that the user will encounter problems with the Actuator System because of inadequate electromagnetic compatibility. However, electromagnetic immunity is always relative and standards anticipate environments of usage. If the user notes unusual behaviour of the Actuator System, in particular if such behaviour is intermittent and associated with the standing right next to mobile phones, microwaves and radio broadcast masts, this could be an indication of electromagnetic interference. If such behaviour occurs, try to move the Actuator System further away from the interfering equipment.

Electromagnetic emission is evaluated on a system level, with the actuator either connected to a LINAK Control Box and accessories or to some customer built electronic control circuitry. If used in other constellations and with external power supply, precautions may be taken to avoid conducted emission.



Warning!

If the actuator or lifting column is used for pull in an application where personal injury can occur, the following is valid:

It is the application manufacturer's responsibility to incorporate a suitable safety arrangement, which will prevent personal injury from occurring, if the actuator should fail.

**Residual risk**

Some of the products contains software based components. LINAK has done various possible efforts to assure that the software is free of errors and that the software has been developed according to the rules of IEC 60601-1-4 (software in Medical products). That involves risk analysis which shows a small residual risk for unwanted/unintended mow of actuators under specific conditions.

According to the above rules it must be informed and if necessary considered in the risk analysis of the final application - More details to residual risk can be provided by LINAK if necessary.

**Warning!**

Note that during construction of applications, in which the actuator is to be fitted, there must be no possibility of personal injury, for example the squeezing of fingers or arms.

**Warning!**

The plastic parts in the system cannot tolerate cutting oil.

**Warning!**

Assure free space for movement of application in both directions to avoid blockade

**Warning!**

Uninstructed personell must not operate the application or the actuator

**Warning!**

In the event of blockage by an obstacle when application is moving inwards, removing the obstacle will cause the load to drop until spindle hits the nut

**Warning!**

Do not turn outer tube

**Warning!**

Do not use chemicals, and inspect yearly for damage and wear.

**Warnings!**

LINAK's actuators and electronics are not constructed for use within the following fields:

- Planes and other aircrafts
- Explosive environments
- Nuclear power generation

**Warning!**

LINAK recommends that the actuators should be used in push applications, rather than pull applications. If the actuator is used for push in an application where personal injury can occur (e.g. patient hoists), a special safety nut must be used. Except for the LA34 which can be used for both push or pull applications, if mounted with safety nuts in both directions.

**Warnings:**

- If faults are observed, the products must be replaced.
- Never spray directly on the products with a highpressure cleaner.

**Warning!**

A LINAK control box must, in the final application, be placed where it is not imposed to any impact. This is to prevent damage by accidentally being struck by an object in the hand of a passer-by or by a broomstick or a mop handle during cleaning the floor. On a medical bed e.g. this might be underneath the mattress support platform. If necessary to mitigate this risk, additional protection might be required.

For actuators without plugs, which are not connected to a LINAK control box, the mains supply or the actuator must always be equipped with an arrangement that switches off the actuator at the end-stop, for example, LS or LSD limit switch. If there is a risk of overloading the actuator, the mains supply must



be equipped with a safety device against overloading (for example a CS16-PCB). If these precautions are not observed, the actuator can be damaged.

The LINAK products cannot tolerate the influence of strong solvents, basic or alkaline liquids.



Non-LINAK handsets

LINAK handsets are designed specially for LINAK control boxes, and they are designed to be highly reliable and flexible. If the customer still wishes to use his own handset, it is important to contact a LINAK sales person to find out the requirements with regard to the switches in the handset. Poor switches can destroy the control box.



The duty cycle printed on the label of the control box must always be noted. If this is exceeded, there is a risk of the control box being overheated and damaged. Unless otherwise specified on the label, the duty cycle is max. 10% : max. 2 min. in use followed by 18 min. not in use. Exceeding the duty cycle will result in a dramatic reduction of the product.



DECLARATION OF INCORPORATION OF PARTLY COMPLETED MACHINERY

LINAK A/S
Smedevænget 8
DK - 6430 Nordborg

Name and address of the person authorized to compile the relevant technical documentation:
John Kling, Group Headquarters, Guderup, DK-6430 Nordborg, email jkl@linak.com

Herewith declares that LINAK Actuators and Actuator Systems comply with the following parts of the Machinery Directive 2006/42/EC, ANNEX I, *Essential health and safety requirements relating to the design and construction of machinery*:

- 1.5.1 Electricity supply; *Directive 2006/95/EC on the harmonization of the laws of Member States relating to electrical equipment designed for use within certain voltage limits.*
- 1.5.10 Radiation, 1.5.11 External radiation; *Directive 2004/108/EC on the approximation of the laws of the Member States relating to electromagnetic compatibility.*

The relevant technical documentation is compiled in accordance with part B of Annex VII and that this documentation or part hereof will be transmitted by post or electronically to a reasoned request by the national authorities.

This partly completed machinery must not be put into service until the final machinery into which it is to be incorporated has been declared in conformity with the provisions of this Directive, where appropriate.

Date: 2010-01-01

Signature:

John Kling
Certification and Regulatory Affairs

1. System description:

Usage/type of applications:

LINAK actuators, lifting columns and electronics have been developed for use in all places where a linear movement is required.

LINAK's products can, for example, be used for:

- Adjustment of beds
- Adjustment of furniture
- Adjustment of table heights and angles
- Patient hoists within the care and hospital sector
- Adjustment of industrial processing machines
- Adjustment of agricultural machines
- Adjustment of ventilation systems
- Adjustment of dentist chairs/gynaecological chairs
- Etc.

The principles of a LINAK system are as follows:

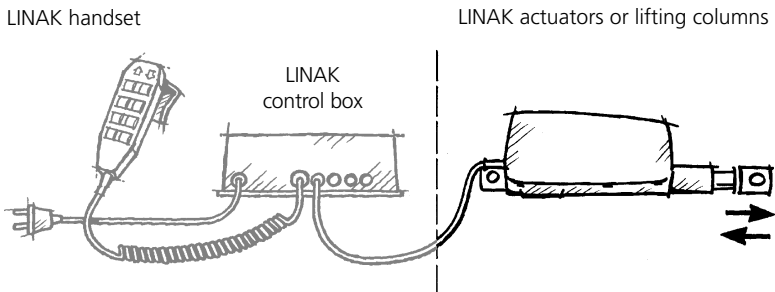

Attention should be paid to the following:

- Control boxes must only be connected to the mains voltage specified on the label. All DIN, jack, or minifit plugs from the CB6S/CB12/CB14/CB16/CB20 IPX6 Washable should be locked by using a LINAK locking mechanism.
- The control box must be connected in such a way that the cables are not trapped, exposed to tension or sharp objects when the application is moved in different directions.

Prior to first use of LINAK batteries, please make sure that they are being charged 24 hours in order to reach proper function and prolong the lifetime of the batteries.

If the customer uses a non-LINAK battery, it is important to check that the current is not reversed (plus and minus swapped over) This applies to both control boxes, which always run off battery and control boxes with battery backup. Contact your nearest LINAK dealer for specification of type, size etc.

The control current in the handset cable must not exceed 100 mA.

The control box is the heart of the system and connects the various outlying units (actuators, lifting columns, handsets and attendant controls). Control boxes differ widely in complexity. The simplest are only able to convert control signals from the handset into operating voltage for the actuator. The most advanced are microprocessor controlled and have advanced functions such as, parallel running of several actuators and other complex correlations. Most LINAK control boxes provide an Electronic Overload Protection (EOP), designed to protect the actuator (excl. LA12, LA29, LA31, LA34), against overload by disconnecting the current when the actuator is fully extended or retracted. If an LA12, LA29, LA31, LA34 actuator is used, the built-in limit switches stop the actuator when fully extended or retracted, and the control box only disconnects when the maximum current is exceeded. When using a CB6S/CB9 control box it is important to note that not all types of CB6S/CB9 have electronic overload protection.

The actuator is the unit, which converts the operating voltage from the control box into a linear movement.

The principle of the LINAK actuator's mode of operation is that a low voltage DC motor (5), via a gear system (12), rotates a threaded spindle, onto which a nut is fitted. As this nut cannot rotate, since the piston rod (2) is restrained, the piston rod will move forwards or backwards, when the threaded spindle rotates.

On the basis of motor type, gearing, and the threaded spindle's pitch, the actuator's thrust and speed are determined.

The handset is the unit to be used when you want the LINAK® system to perform a movement. It determines whether the control box will make the actuator move in or out. There are many variants of LINAK handsets.

The Attendant Control (ACC, ACK, ACL, ACM, ACP, ACO) is an accessory used when nursing staff want to restrict the patients adjustment options of a bed. It is often used in conjunction with a handset and disables selected functions on the handset. It can also have control functions with the same function as those on the handset.

Fundamental actuator construction

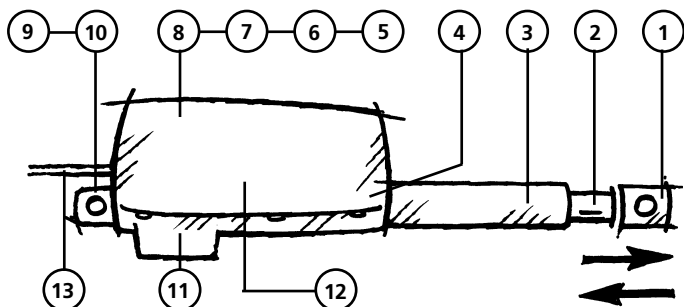

- | | |
|-----------------------------------|---|
| 1. Piston rod eye | 7. Motor with potentiometer |
| 2. Piston rod | 8. Motor with reed-switch |
| 3. Location of mechanical splines | 9. Back fixture |
| 4. Location of brake | 10. Back fixture with electrical splines |
| 5. Motor | 11. Quick release mechanism |
| 6. Motor with optical switch | 12. Transmission between motor and spindle |
| | 13. Cable for connection to 12/24/36V DC by means of plug via control box |

Warranty and service life

The LINAK warranty covers manufacturing defects in the products, starting from the date of manufacture. There is 36 months' warranty on the HOMELINE products, 18 months' for MEDLINE and CARELINE products, and 12 months' for the TECHLINE products. The warranty is limited to the value of the LINAK product.

LINAK's guarantee is only valid so far as the products have been used and maintained correctly and has not been tampered with. Furthermore, the products must not be exposed to violent treatment. In the event of this, the warranty will be ineffective / invalid. LINAK's warranty is only valid if the system is unopened and has been used correctly.

All LINAK products are designed to have an optimum service life as a matter of course, but the expected service life in a specific application is very dependent on how the products are used.

IP Protection degree:

The products can be cleaned as follows according to their IP protection, which is stated on the product label. The IP code specifies the degrees of protection provided by the enclosures. For most products only the protection against ingress of water (second characteristic numeral) is specified, ingress of solid foreign objects or dust (first characteristic numeral) is not specified and therefore replaced by the letter X in the code. For some special industrial products both the first and second characteristic numerals are specified. This is a demand from the marked and will only be specified if tested and approved.

IP protection	Cleaning instructions
IPX0	Clean with a damp cloth
IPX1	Clean with a damp cloth
IPX2	Clean with a damp cloth
IPX3	Clean with a damp cloth
IPX4	Clean with a damp cloth
IPX5	Wash with a brush and water, but not water under pressure
IPX6	Wash with a brush and water. The water can be under pressure, but the system must not be hosed down directly with a highpressure cleaner. Max. 20°C
IPX6 Washable*	Clean by the use of wash tunnels
IPX6 Washable according to IEC 60601-2-52	Clean by the use of wash tunnels according to IEC 60601-2-52

* IPX6 Washable products can be washed in wash tunnels according to the following guidelines :

- The distance between the nozzle and the electrical parts must be at least 300 mm.
- The handset and motor plug must be pushed right in.
- The water temperature must not exceed 65°C in max. 3 minutes
- Cooling with cold water is not permitted.

To avoid degreasing of the piston rod, the actuator should be retracted to minimum stroke before washing.



Warning!

The systems must not be sprayed directly with a highpressure cleaner.



Warning!

Interconnecting cables must remain plugged in during cleaning to prevent the ingress of water.



Warning!

Cleaning with a steam cleaner is not permitted.

LINAK washing procedure for IPX6 Washable products:

Reference: The LINAK washing procedure is defined to duplicate the washing process of a hospital using a wash tunnel. This washing process has been chosen, as it sets a high standard regarding the sealing effectiveness of the products.

Chemicals: Use the Ecolab product Sekumatic FRE or a similar product with corresponding properties as detergent. Use the Ecolab product Sekumatic FKN or a similar product with corresponding properties as softener.

Design: The LINAK washing machine is built with a large washing chamber containing more shelves, onto which the test products can be placed. Each shelf is surrounded by sprayjet rotor, they spray the test products from above and below, so that all surfaces of the test products are sprayed upon.

For more details see the picture below:

Data for the LINAK development department's test-washing machine.

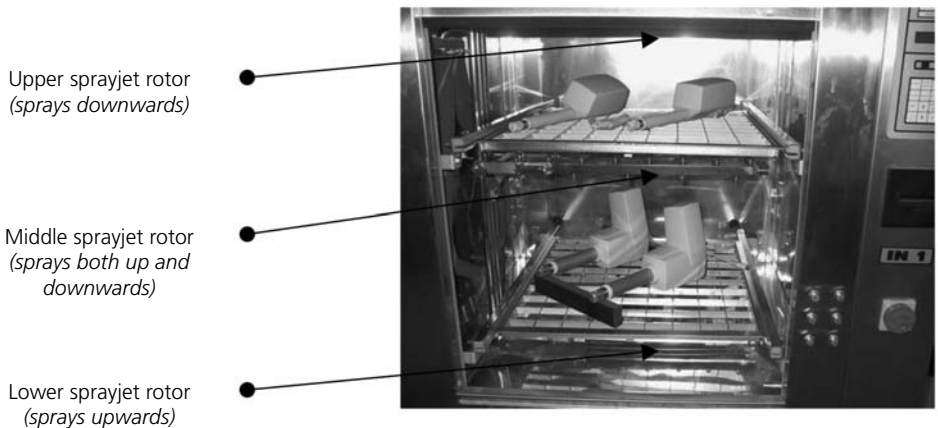

Water volume: Each of the sprays supplies approx. 6 litres of water pr. minute, the equivalent of the test products on each of the shelves being sprayed with a total of approx. 75 l/min. Both during the washing process and during the rinsing process.

Spray pressure: Both during the washing process and the rinsing process the washing machine operates with a spray pressure of 0,4 bar. (overpressure)

Temperature: The water temperature in both washing and rinsing is constant at 65°C. During the first 2 minutes the products are washed with 65° warm water and are here warmed up. After a few seconds the products are rinsed with 65° warm water for one minute and then cooled down in the ambient air temperature for about 15 minutes. A total cycle lasts for about 20 minutes. The diagram below is a graphic illustration of the process.

If LINAK products with the IP protection class IP66 Washable go through a washing process which differs considerably from the above, there will be no guarantee for either the function or the life of the product.

Comparison between temperature profile for LINAK and reference washing process from a hospital with a washing tunnel.

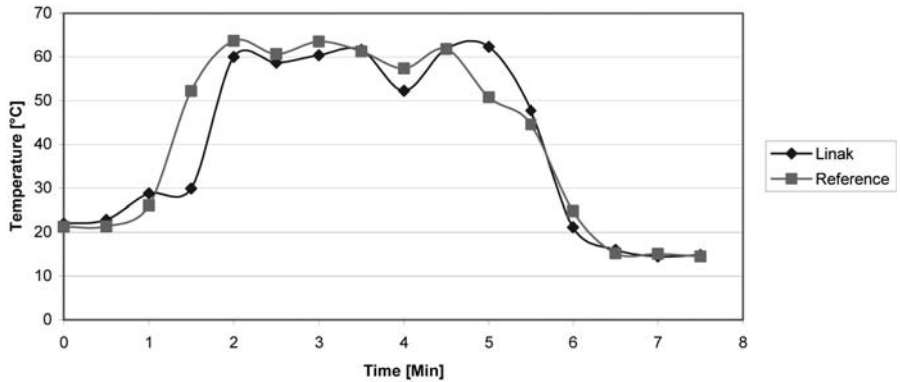

- Actuators are tested in the closed (run inwards) position.
- CB's are tested with plugs fitted.
- The washing cycle is repeated 200 times during each test.

Cable Wash

Before the washing procedure starts!

In order to maintain the flexibility of the cables, it is important that the cable is placed in such a way that the cable's own weight does not strain the coil during the washing process.

This can be done by placing the cable ON the bed or another form of support for the cable.

Please see the examples in the below pictures



Maintenance

Valid for all LINAK products

- The LINAK products must be cleaned at regular intervals to remove dust and dirt and inspected for mechanical damage, wear and breaks.
- The LINAK products are closed units and require no internal maintenance.
- Only type IPX6 is waterproof and type IPX6 Washable tolerates being washed in tunnels.
- The LINAK products must be IPX6 Washable when cleaning in wash tunnels. Make sure that the plugs are correctly fitted with O-rings before washing.
- **O-rings:** When individual parts are replaced in a LINAK IPX6 or IPX6 Washable system, the O-rings on all parts, must be replaced at the same time. On control boxes with a replaceable mains fuse, the O-ring in the fuse cover must be replaced every time the cover has been removed. The O-rings must be greased in water free vaseline when replacing them. Make sure that the counterpart - the socket - is clean and undamaged.

Valid for all LINAK actuators and lifting columns

- Actuators/lifting columns must be inspected at attachment points, wires, piston rod, cabinet, and plugs, as well as checking that the actuator/lifting columns function correctly.
- To ensure that the pregreased inner tube remain lubricated the actuator must only be washed down when the piston rod is fully retracted.

Valid for all LINAK control boxes and handsets

- Electronics must be inspected at attachment points, wires, cabinet, and plugs.
- Inspect the connections, cables, cabinet, and plugs, and check for correct functioning (does not apply to battery versions).
- With the exception of the CS16 the control box is sealed and maintenance free.
- Inspect at regular intervals that the ventilation aperture on the external battery is positioned correctly and is intact throughout its length, approx. 20 mm., **see figure 1**.

Environmental conditions:

Storage and transport	
Operating :	
Temperature Relative humidity Atmospheric pressure	5°C to 40°C 20% to 90% @ 30°C – not condensing 700 to 1060 hPa
Storage :	
Temperature Relative humidity Atmospheric pressure	-10°C to +50°C 20% to 90% @ 30°C – not condensing 700 to 1060 hPa
Transport :	
If the actuator is assembled in the application and is exposed to push or pull during transportation, the actuator can be damaged. Do not drop an actuator or otherwise damage the housing during disassembly or transportation. We do not recommend using an actuator which has been damaged.	

Valid where nothing otherwise is stated under the specific products in a later section.

Insulation class:

LINAK control boxes are available in insulation class 1 and insulation class 2.













Class 1 means with earth connection

Class 2 means without earth connection

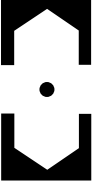
When measuring the resistance in the earth connection in LINAK Control Boxes (class 1), it is recommended to use equipment, delivering a test current of no less than 5A. The resulting voltage will correspond to the resistance in the earth connection. Test currents below 5A, would yield no exact measurements.

Key to symbols









The following symbols are used on the label on the LINAK products.

	Type B equipment, as per EN 60601-1		Lock function
	Protection against contact/foreign matter (first character) and water (second character) as per EN60529		Release function
	Class 2 equipment		Charge indicator
	For indoor use		Safety switch/enable button
	Safety isolating		
	Protective earth		
	Alternating Current		
	Direct current		
	Attention, consult accompanying documents		

	Demko approval
	Fimko approval
	
	
APPROVAL V94265	Australian approval mark
APPROVAL NO.:97122	Australian approval mark
	Recognised - Component Mark
	Canadian Recognised - Component Mark
	Recognised Component Mark for Canada and the United States
	T-Mark
	RW-Tüv approval
	TÜVRheinland
	
	TÜV Product Service
	ETL
	C-ETL
CS95145V	
LGA 	LGA
	UL Listing Mark
	C-UL Listing Mark
	C-UL US Listing Mark
	UL Listing Mark

File E97199 UL file number
File E175209 UL file number
File E151104 UL file number



	Product with a thermofuse
	For indoor use (House).
	Safety isolating transformer.
	Electronics scrap
	Equipment Kl.2 (Double square)
	Patient part of type B (Mand)
	Patient part of type BF
	Earth protective
KL.1	Equipment class1.
	Earth

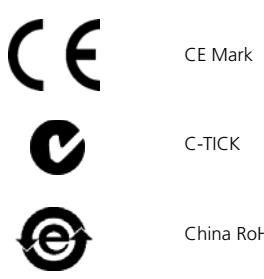

Mounting:

Actuator:

Do not use any other screws for the mounting brackets than those recommended by LINAK. If longer screws are used they will come into contact with the inner parts of the actuator. This will result in an irregular operation or even damage the actuator.

During mounting, the actuator must always be:

- Fixed, to protect it against torque and bending. **See Figure 2.**
- Fixed, so that it is restrained, but free to move on its mountings. **See Figure 3.**
- Fixed in brackets, which can take up the torque reaction. **See Figure 3.**
- Mounted at right angles, so that the right angle requirement is observed. **See Figure 4.**
- Mounted with correct bolt dimension.
- Mounted with bolts and nuts made of high quality steel grade (e.g. 10.8). No thread on bolt inside back fixture or piston rod eye.
- Bolts and nuts must be protected from being able to fall out.
- Inspect the actuator for damage before mounting. Damaged actuator must not be mounted. Watch e.g. for damaged packaging.
- Do not use a too high torque when mounting the bolts for back fixture or piston rod eye

Control boxes:

- The mounting screws on the control box must be tightened with a maximum torque of 1 Nm
- The mounting surface to which the control box is attached should have a surface evenness better than ± 0.5 mm.
- Systems must not be installed/deinstalled while in operation.
- Control boxes with a wet alarm must be mounted as shown on figure 5.
- Nuts and bolts must be made of steel.
- Nuts and bolts must be tightened securely.

The correct bolt size for securing the CB8, CB12, CB14, CB16 and CB20, is $\varnothing 5$ mm and the ACP box is M5.



Cables:

It is important to remove the transport plastic bag before using the cable.

Cables need to be fixed to the application or to be placed in such a way that users cannot stumble and injure themselves.

Connecting the system:

Do not connect the mains cable until all actuators and handsets have been connected to the control box. Start by connecting the handset to the control box. The connection in the control box is marked with "HB".

Connect the different actuators to the different channels on the control box. Each channel is marked with a number (e.g. "1", "2", "3".....).

Check that all plugs are well connected and firm pushed into the connection plug. Due to the fact that LINAK control boxes are designed for a high IP degree a firm force can be required.

Connect the mains cable.

The actuators can now be operated by pushing a button on the handset. Use only one button at the time. If the control box is equipped with a special software an initializing process might be necessary. This process is described in the software specification.

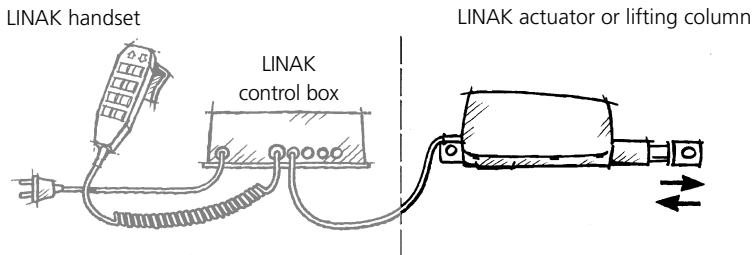

Attention should be paid to the following:

- Control boxes must only be connected to the mains voltage specified on the label. All DIN, jack or minifit plugs from the CB6S/CB12/CB14/CB16/CB20 IPX6 Washable should be locked by using a LINAK locking mechanism.
- The control box must be connected in such a way that the cables are not trapped, exposed to tension or sharp objects when the application is moved in different directions.

Prior to first use of LINAK batteries, please make sure that they are being charged 24 hours in order to reach proper function and prolong the lifetime of the batteries.

If the customer uses a non-LINAK battery, it is important to check that the current is not reversed (plus and minus swapped over) This applies to both control boxes, which always run off battery and control boxes with battery backup. Contact your nearest LINAK dealer for specification of type, size etc. The control current in the handset cable must not exceed 100 mA.

Any non-detachable power supply cord with mains plug is considered as the disconnecting device.

Charging is only allowed in dry environment, and appliance inlet must be thoroughly dried before connecting to mains.

All types of actuators may only be connected according to the label, where the voltages 12, 24, or 36 VDC are indicated.

- a) Actuators with jack plugs may only be connected to LINAK control boxes
- b) Actuators without plugs are connected as shown in **Figures 6.1 - 6.12**.

For actuators operating without a control box, the mains supply of the actuator must be equipped with an arrangement, which switches off the actuator at end-stop (e.g. LS or LSD limit switch). If there is a risk of overloading the actuator, the mains supply must be equipped with a safety device against overloading (e.g. a CS16 PCB). If this requirement is not observed, the actuator may be damaged.

Actuators with internal control PCBs are not first failure safe if used in a system combination without power request (power for actuator switched ON only when handset key active).

JUMBO system (special information):

The LINAK JUMBO system is specially developed for patient lifts, offering various combinations of actuators and control boxes.

Connecting the system:

Mount the mounting bracket (MBJ) to the application. Mount control box and battery (and charger (CHJ2) if equipped).

If it is a JUMBO Home system mount the control box on the application (no mounting bracket is needed). Only vertical mounting allowed (connectors facing downwards).

Connect the handset to the control box. The connection in the control box is marked with "HB".

Connect the actuators to the control box. Each channel is marked with a number (e.g. "1", "2"). Channel "1" has always to be used for the High / Low (Lifting) function.

The actuators can now be operated by pushing a button on the handset. Use only one button at the time.

Example of JUMBO patient lift system

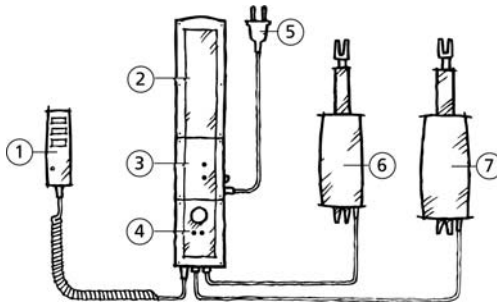

- | | |
|-----------|-----------------|
| 1 Handset | 4 Control box |
| 2 Battery | 5 Mains plug |
| 3 Charger | 6 + 7 Actuators |

System components:

Actuators, types LA28, LA32, LA34, LA44

Control Box, types CBJ1/CBJ2, CBJC

Batteries, types BAJ1, BAJ2

Handsets, types HB5, HB7, HB8

Battery Charger CH01

Configuration of the JUMBO System

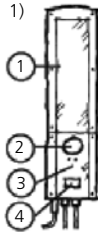

- ① Battery
- ② Emergency stop
- ③ Control box
- ④ LCD-display for battery condition

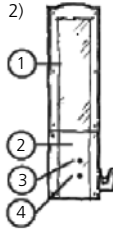

- ① Battery
- ② Charger
- ③ Light indication for mains connection
- ④ Light indication for charging

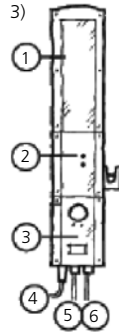

- ① Battery
- ② Charger
- ③ Control box
- ④ Output for hand
- ⑤ + ⑥ Output actuator

JUMBO Home System

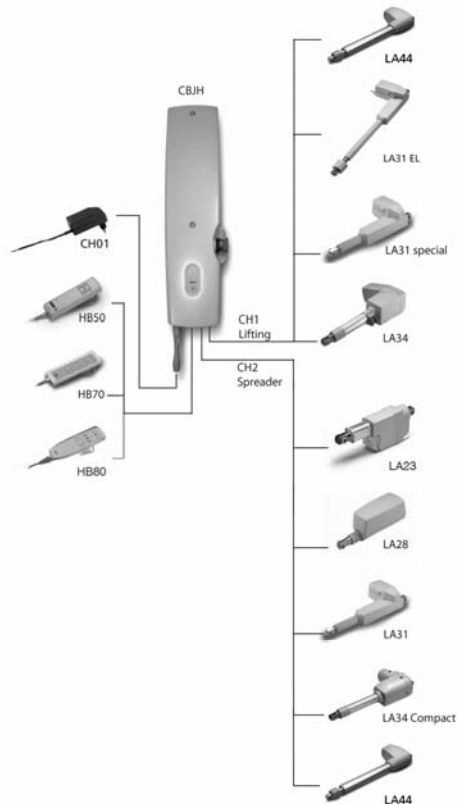

2. Information on start-up, de-installation and operation:

Before installation, de-installation, or troubleshooting:

- Stop the actuator/lifting column.
- Switch off the power supply or pull out the mains plug and pull out the plug to the actuator/lifting column.
- Relieve the actuator/lifting column of any loads, which may be released during the work.

Prior to first use of LINAK batteries, please make sure that they are being charged 24 hours in order to reach proper function and prolong the lifetime of the batteries.

Before start-up:

- Make sure that the system has been installed as instructed in the User Manual.
- The individual parts (actuator/lifting column/handsets etc.) must be connected before the control box is connected to the mains.
- Make sure that the voltage of the mains to be connected to the product or the system is the one stated on the label.
- Make sure that the actuator/lifting column is connected to a mains electricity supply/transformer with the correct voltage and which is dimensioned and adapted for the actuator in question.
- The equipment can be freely moved over the actuator/lifting column's whole working area.
- Check correct function after mounting.
- The actuator/lifting column must not be loaded in excess of the values indicated in the specifications on the product label.
- The duty cycle noted on the product label must always be noted. Otherwise there is a risk of damaging the products. Exceeding the duty cycle will result in a dramatic reduction of the life time of the system. Unless specified otherwise on the product label the duty cycle is max. 10% : Max. 2 minutes in use followed by 18 minutes not in use.
- The actuator/lifting column system may only be used in an environment corresponding to the system's IP-rating. LINAK products are marked with the actual IP-rating on the label.

During operation:

- Listen for unusual sounds and watch out for uneven running. Stop the actuator/lifting column immediately if anything unusual is observed.
- If the control box makes unusual noises or smells, switch off the mains voltage immediately and the external battery, if any.
- Take care that the cables are not damaged.
- Unplug the mains cable on mobile equipment before it is moved.

Troubleshooting

Actuators/lifting columns Symptom	Possible cause	Action
No motor sound or movement of piston rod	<ul style="list-style-type: none"> - The actuator is not connected to the control box - Blown fuse in the control box - Cable damaged 	<ul style="list-style-type: none"> - Connect the actuator to the control box - Fuse must be changed - Send actuator for repair
Excessive electricity Consumption		<ul style="list-style-type: none"> - Send actuator for repair
Motor runs but spindle does not move	<ul style="list-style-type: none"> - Gear wheel or spindle damaged 	<ul style="list-style-type: none"> - Send actuator for repair
Actuator cannot lift full load	<ul style="list-style-type: none"> - Clutch is worn - Motor is damaged 	<ul style="list-style-type: none"> - Send actuator for repair
Motor sound but no movement of piston rod		<ul style="list-style-type: none"> - Send actuator for repair
No signal from Reed or Hall switch		<ul style="list-style-type: none"> - Send actuator for repair
Motor runs and quick release does not function or is noisy	<ul style="list-style-type: none"> - Declutching arm turns less than approx. 75° 	<ul style="list-style-type: none"> - Adjust cable
Piston rod will only move inwards and not outwards	<ul style="list-style-type: none"> - Safety nut has operated 	<ul style="list-style-type: none"> - Send actuator for repair
Motor runs too slowly or does not give full force	<ul style="list-style-type: none"> - Insufficient power supply - Voltage drop in cable 	<ul style="list-style-type: none"> - Increase power supply - Thicker cable

Electronics

Symptom	Possible cause	Action
Power indicator does not light up	- Not connected to mains	- Connect to mains
	- The fuse has blown	- Replace fuse, if the system is prepared for external fuse replacement, or send the system for repair
	- Defective power cable	- On control boxes with exchangeable power cable change the cable. - On control boxes with fixed cable send it for repair
	- Control box defective	- Send control box for repair
Power indicator lights up, but actuator does not run	- Actuator plug not pushed into control box properly	- Push actuator plug into control box properly
Relays in control box are heard clicking	- Actuator defective	- Replace actuator - Control box defective - Replace the control box
Power indicator lights up, but actuator does not run	- Control box defective	- Send control box for repair
No relay noise is heard from control box Not valid for CB20/CB6S OBF/CB16 OBF	- Handset defective	- Send handset for repair
Control box completely dead on battery and no relay clicking is heard	- Battery completely flat	- Charge battery
	- Battery defective	- Replace battery
Actuator does not run on battery, but relay clicking is heard	- Actuator plug not properly pushed into control box	- Push actuator plug properly into control box
	- Actuator defective	- Replace actuator
	- Control box defective	- Replace control box
Control box okay apart from one direction on one channel	- Handset defective	- Send handset for repair
	- Control box defective	- Send control box for repair

3. Information on specific actuators :

1. LA12 (TECHLINE™)

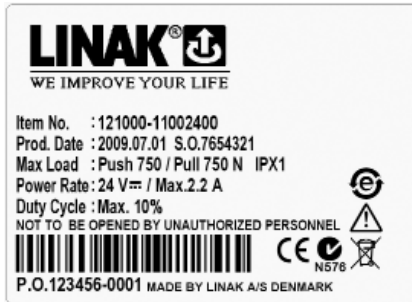

Thanks to the small size and outstanding performance, the LA12 actuator provides a practical and cost-effective alternative to traditional pneumatic systems and gear motors.

The LA12 is ideal for automating industrial and agricultural machines, feeding, ventilation systems troughs and many other applications requiring short linear movement.

Installation instructions

The actuators model LA12 must be installed in a fixed position.

Reed-switch:

Reed-switch gives a number of pulses for each rotation of the motor. These pulses are used to calculate the piston rod's position as well as to control several actuators running in parallel.

Your nearest LINAK dealer can inform the number of pulses per stroke length.

Regarding Reed-switch connection, **see Figure 6.4** (LA12R)

If the LA12 actuator is mounted in an application where a mechanical stop prevents the installed end-stop switches in LA12 from being activated, the LA12 actuator must be equipped either with an electrical safety device, a timer or an electronic limit switch. Therefore, please contact your nearest LINAK dealer for technical data.

Built-in end-stop circuit

The end-stop switch is part of the actuator construction. Each time the actuator reaches end-stop position the switch is activated and the current is cut off.

2. LA22 (MEDLINE® CARELINE® TECHLINE™)

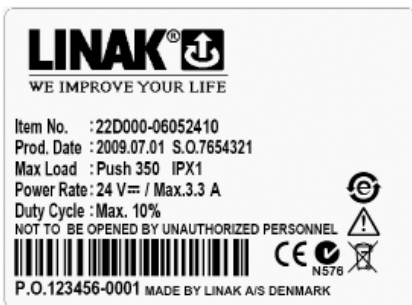

The LA22 is an in-line actuator specially designed with a small overall dimension for easy use in industrial, agricultural, and rehabilitation products.

Thanks to its small outer dimensions and linear design, the LA22 is well suited for applications where installation space is limited, such as on wheelchairs.

3. LA23 (MEDLINE® CARELINE® TECHLINE™)

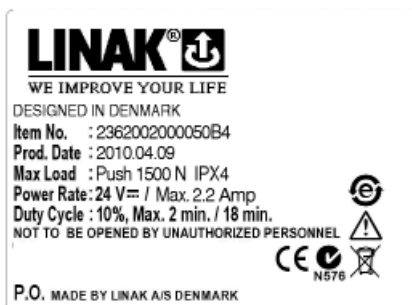

The LA23 is a small and strong push/pull actuator (up to 2500N). LA23 can be used in various applications where size is important. The actuator does have build in electrical limit switches and guided nut.

Precautions:

- Duty cycle: 10%, 2 minutes driving followed by 18 minutes pause
- Usage temperature -30°C to +55°C
- Storage temperature -45°C to +70°C



Warnings!

- Do not sideload the actuator.
- Do only use the actuator within specified working limits.
- Always use steel backfixture for LA23 2500N versions and for pull load.
- The B and G 24V motors must only be used with their respective control box types.
 - Motor type A: 12V motor
 - Motor type B: 24V motor which must be used with JUMBO; CBJ1/2, CBJC and CBJH or generally in applications which are **mainly driven with battery**
 - Motor type G: 24V motor which must be used with OpenBus control boxes; CB20, CB16, CB6s.

- Instruction concerning turn of the piston rod eye:

When mounting and taking the actuator into use, it is not permitted to make excessively many turns of the piston rod eye. In cases where the piston rod eye is not positioned correctly, it is permitted to first screw the eye down to its bottom position (1), and thereafter a maximum half turn outwards again (2):

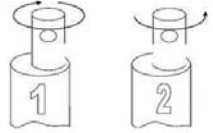

- If stroke is less than 50 mm and the outer limit switch fails it will be possible to drive the actuator up to stroke of 52 mm before the mechanical end stop take effect. Please make sure that the application can withstand this in a safe way.
- When mounting the LA23 in the application ensure that the bolts can withstand the wear and that they are secured safely.
- Do not place load on the actuator housing and do prevent impact or blows, or any other form of stress to the housing.



Recommendations:

- Ensure that the cable lock is mounted correct.
- Ensure that the duty cycle and the usage temperatures for LA23 actuators is respected
- Ensure that the cable cannot be squeezed, pulled or subjected to any other stress.
- If a cable lock has been removed it is recommended to check if it is has been damaged during removal. If so it is recommended to replace with a new one.
- Before mounting a cable, ensure that the cable, cable plug or o-ring is not damaged. If damage is observed, the cable must be replaced with a new one.

Below you see an instruction in how to mount and remove the cable lock from LA23.

a) Mount a cable lock:

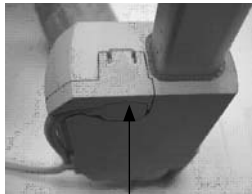

Push down until the cable lock click

b) Remove a cable lock:

Picture 1:

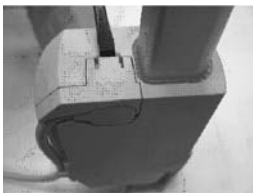

Insert e.g. a screwdriver in a 45° angle as illustrated on picture 1

Picture 2:



Turn to release

Picture 3:

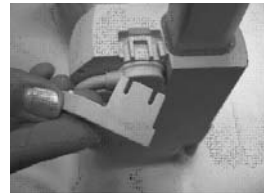

Remove by hand

Connection diagrams:

Basic LA23

LA23XXXXXX00XXXXX

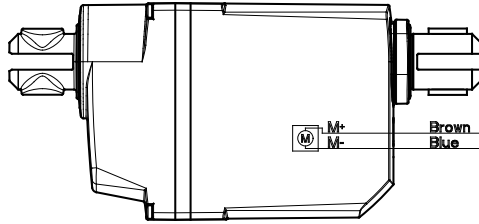

LA23 with potential free end stop

LA23XXXXXX01XXXXX

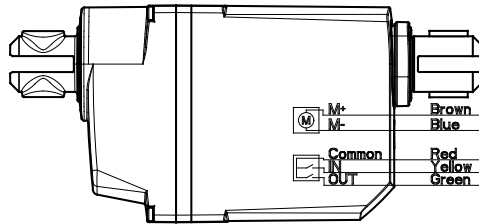

LA23 with standard dual hall

LA23XXXXXX02XXXXX

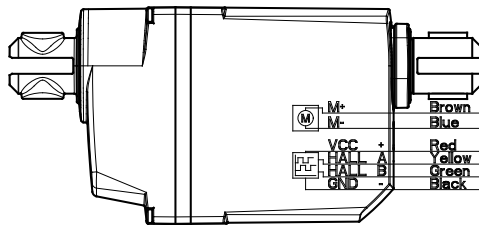

LA23 with analog position feedback and potential free endstop.

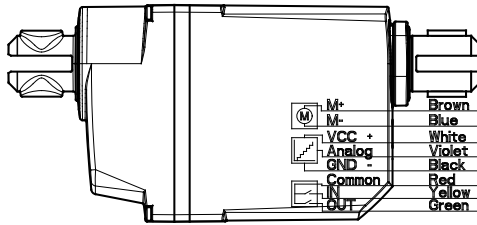

LA23 with analog position feedback

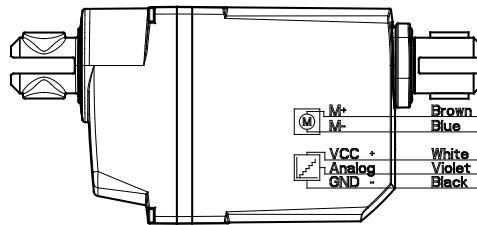

LA23 with PWM position feedback and potential free endstop

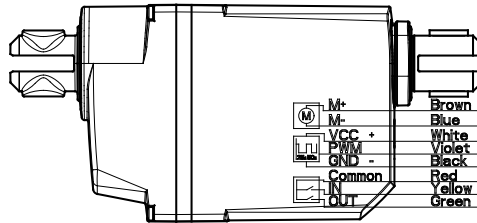

LA23 with PWM position feedback

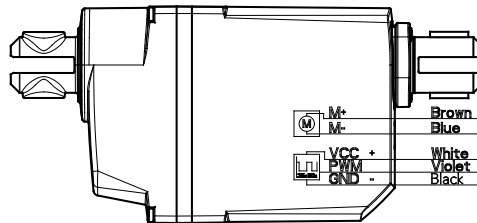

Note:

For actuators connected to LINAK CB's:

If reversed driving is wanted this have to be done with special cables.

Please contact LINAK if needed.

For actuators with hall analog or PWM positioning feedback:

Limit supply to 500 mA or 500 mA Fuse in case of wrong polarisation.

3. LA27 (MEDLINE® CARELINE® HOMELINE®)



The LA27 actuator is a powerful actuator designed for applications such as furniture and care beds.

Built-in end-stop circuit (CS27)

In the LA27/CS27 the actuator is switched off at the end position. There is no overcurrent protection.

- The LA27CS27 has no IP classification and is connected to a HB71 or HB72. The power supply is the TR6 or TR7.

It is important that the supply voltage 24 VDC is connected correctly (see **Figure 6.7**) otherwise the CS-circuit may be destroyed.

Mechanical spline:

The splines function so that the actuator can only push, not pull.

During pull in the actuator, the inner tube is lifted off the thread bush, and the actuator can therefore never pull a load, only push.

Functional test of mechanical splines:

When the piston rod is at the innermost position, it must be possible to pull it out manually to its full travel length and to press it in again without much resistance and without using the motor. If this is not possible, contact your nearest LINAK dealer.

Quick Release:

The LA27 with QR is designed to be used as a part of the backrest function in a Care/Hospital bed. The QR function allows a patient to be lowered manually to a flat position very quickly (CPR) in case of an emergency.

Functional test of QR:

To test a LA27QR it is necessary to have the actuator built into an application. The release cable has to be provided and mounted by the customer.

The necessary force on the cable required to operate the Quick Release is approx. 20 kg.

The necessary force on the actuator to operate the quick release is approx. 50 kg. When operating the QR, it is recommended that the QR is activated all the way down.



Warning!

- If the actuator does not work as described above, the risk of injury due to squeezing can arise. The actuator must therefore immediately be sent for service at the nearest, authorised LINAK workshop.
- The actuator must not be used in pull applications when the quick release is activated, as the risk of personal injury can arise.
- Do only use the actuator within specified working limits.
- Do not sideload the actuator.

4. LA28 (MEDLINE® CARELINE® TECHLINE™)

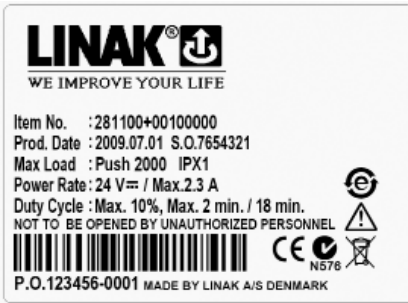

The LA28 is primarily a system actuator. The actuator is very quiet and powerful designed for use in the furniture, rehabilitation, and hospital bed line of businesses.

The actuator is also ideal for use in agricultural machinery and for a wide range of industrial applications.

Reed-switch:

Reed-switch gives a number of pulses for each rotation of the motor. These pulses are used to calculate the piston rod's position as well as to control several actuators running in parallel.

Your nearest LINAK dealer can inform the number of pulses per stroke length.

Regarding Reed-switch connection, **Figure 6.8** (LA28R)

Built-in end-stop circuit (CS28/CS28S)

In the LA28 actuator, with built-in CS28 A-, B- or C-PCB, the actuator is switched off at the end position or when overloaded.

LA28 actuator with:

- The CS28 A is standard IPX1 and is connected to a HB41 handset with a telephone plug.
- The CS28 B is standard IPX5 and is connected to a HB41 handset with a DIN plug. CS32 B is also available in IPX6.
- The CS28 C is standard IP51 and is connected to an external contact or control. **See figure 6.7.**

Mechanical spline:

The splines function so that the actuator can only push, not pull.

During pull in the actuator, the inner tube is lifted off the thread bush, and the actuator can therefore never pull a load, only push.

Functional test of mechanical splines:

When the piston rod is at the innermost position, it must be possible to pull it out manually to its full travel length and to press it in again without much resistance and without using the motor. If this is not possible, contact your nearest LINAK dealer.



Warning!

Do only use the actuator within specified working limits.

5. LA29 (HOMELINE®)



The LA29 actuator is a HOMELINE® actuator, specially made for domestic applications like recliners.

The actuator has a very short installation dimension as the distance between the two fixing points is small when the actuator is retracted and at the same time independent of the stroke length.

Reed switch:

The Reed switch gives a number of pulses for each rotation of the motor. These pulses are used to calculate the position as well as to control several actuators running in parallel.

Your nearest LINAK dealer can inform the number of pulses per stroke length.

Regarding Reed-switch connection, **see Figure 6.10.**

Hall

The Hall principle is very similar to the Reed principle. A Hall sensor is based on a magnet that rotates. Two hall sensors are placed close to the magnet field. The control box (CB20/CB6S OBF/CB16 OBF/CBD4/CBD5) can detect whenever the magnetic field changes direction. The two Hall sensors are placed close to each other, but with a small displacement. This distance leads to a timing difference between the two pulses. Whichever one of them comes first indicates the direction of movement. Therefore, there will be no error summary (as with the reed switch) Hall is therefore a very precise system. Hall is not suitable for use in quick release actuators - **see figure 10.**

Built-in end-stop circuit

The end-stop switch is part of the actuator construction. Each time the actuator reaches end-stop position the switch is activated and the current is cut off.



Warning!

Do only use the actuator within specified working limits.

6. LA30 (MEDLINE® CARELINE® TECHLINE™)



The LA30 is a powerful actuator yet small enough to fit most applications.

The actuator can be supplied with options such as built-in potentiometer for servo operation or an extra powerful motor for increased speed and strength (S-motor).

In addition to industrial and agricultural applications, the actuator is also ideal for positioning satellite dishes.

Reed-switch:

The Reed-switch gives a number of pulses for each rotation of the motor. These pulses are used to calculate the piston rod's position as well as to control several actuators running in parallel.

Your nearest LINAK dealer can inform the number of pulses per stroke length.

Regarding Reed-switch connection, **see Figure 6.10.**

Mechanical spline:

The splines function so that the actuator can only push, not pull.

During pull in the actuator, the inner tube is lifted off the thread bush, and the actuator can therefore never pull a load, only push. **See Figure 8.**

Functional test of mechanical splines:

When the piston rod is at the innermost position, it must be possible to pull it out manually to its full travel length and to press it in again without much resistance and without using the motor. If this is not possible, contact your nearest LINAK dealer.



Warning!

Do only use the actuator within specified working limits.

7. LA31 (MEDLINE® CARELINE® TECHLINE™ HOMELINE® DESKLINE®)



The LA31 actuator is a very quiet and powerful actuator designed for a variety of applications such as furniture, care, or hospital beds.

The standard LA31 actuator is available for both the HOMELINE®, CARELINE®, TECHLINE™ and DESKLINE® product ranges.

Reed-switch:

The Reed-switch gives a number of pulses for each rotation of the motor. These pulses are used to calculate the piston rod's position as well as to control several actuators running in parallel.

Your nearest LINAK dealer can inform the number of pulses per stroke length. Regarding Reed-switch connection, **see Figure 6.10.**

Hall

The Hall principle is very similar to the Reed principle. A Hall sensor is based on a magnet that rotates. Two hall sensors are placed close to the magnet field. The control box (CB20/CB6S OBF/CB16 OBF/CBD4/CBD5) can detect whenever the magnetic field changes direction. The two Hall-sensors are placed close to each other, but with a small displacement. This distance leads to a timing difference between the two pulses. Whichever one of them comes first indicates the direction of movement. Therefore, there will be no error summary (as with the reed-switch) Hall is therefore a very precise system. Hall is not suitable for use in quick release actuators. **see figure 10.**

Built-in end-stop circuit

In the actuators mentioned the end-stop switch is part of the actuator construction. Each time the actuator reaches end-stop position, the switch is activated and the current is cut off.

External Quick Release

The quick release function is placed in the piston rod end, in which a wrappedspring clutch can be loosened by means of turning the spring housing either by the handle or a cable. Hereafter, the inner tube can turn freely and due to the pressure on the piston rod end from the application, the inner tube will rotate and thus screw itself downwards.



Warning!

- If the actuator does not work as described above, the risk of injury due to squeezing can arise. Therefore, the actuator must immediately be sent for service at the nearest, authorised LINAK workshop.
- The actuator must not be used in pull applications when the Quick Release is activated, as the risk of personal injury can arise.
- Do only use the actuator within specified working limits.
- Bowden cable cover must click twice, in order to be locked sufficiently
- Do not sideload the actuator
- Inspect the actuator minimum once a year for wear and jarring sound

Internal Quick Release:

The LA31 with Quick Release is designed to be used as a part of the backrest function in a Care/Hospital bed. The Quick Release function allows a patient to be lowered manually to a flat position very quickly (CPR) in case of an emergency.

New version of Quick Release (Internal Quick Release).

The new version of the Quick Release is integrated in the clutch of the LA31.

It operates by way of a release cable that is pulled. Hereafter, the clutch is declutched and the spindle can turn freely. Due to the pressure on the piston rod end from the application, the spindle will rotate thus moving the actuator inwards.

Due to this new version the LA31 actuator can keep its standard installation dimension and has a protection class up to IPX6 washable.

The Quick Release is e.g. used for emergency lowering of the headrest part of a bed.

Functional test of QR:

To test a LA31QR it is necessary to have the actuator built into an application. The release cable has to be provided and mounted by the customer. The necessary force on the cable required to operate the Quick release is approx. 5 kg. The necessary force on the actuator to operate the Quick Release is approx. 50 kg. When operating the Quick Release, it is recommended that the Quick Release is activated all the way down.

Mechanical spline:

The splines functions so that the actuator can only push, not pull.

During pull in the actuator, the inner tube is lifted off the thread bush, and the actuator can therefore never pull a load, only push. See figure 8.

Functional test of mechanical splines:

When the piston rod is at the innermost position, it must be possible to pull it out manually to its full travel length and to press it in again without much resistance and without using the motor. If this is not possible, contact your nearest LINAK dealer.

8. LA32 (MEDLINE® TECHLINE™)



The LA32 actuator is a powerful actuator that can be supplied with a ball screw spindle to give outstanding performance. The ideal choice for a wide range of applications including adjustment of hospital beds.

The LA32 actuator has many special options including a safety nut, splines, quick release (F) and an optional protection up to IPX6 standard.

Reed-switch:

The Reed-switch gives a number of pulses for each rotation of the motor. These pulses are used to calculate the piston rod's position as well as to control several actuators running in parallel.

Your nearest LINAK dealer can inform the number of pulses per stroke length.

Regarding Reed-switch connection, **see Figure 6.10.**

Freewheeling of piston rod

All LA32 actuators with freewheeling as well as with quick release have the designation W on the label.

The function causes the following:

- The piston rod can be pulled out with a thrust of approx. 300 N and it remains in the new position without declutching.
- The actuator cannot pull, but only push.

Functional test:

It must be possible to pull the piston rod out with a thrust of approx.

300 N and it must remain in the new position without releasing. If this is not possible, contact your nearest LINAK dealer.

Built-in end-stop circuit (CS32)

In the LA32 actuators, with built-in CS32 A-, B- or C-PCB, the actuator is switched off at the end position or when overloaded.

LA32 actuator with:

- The CS32 A is standard IPX1 and is connected to a HB41 handset with a telephone plug.
- The CS32 B is standard IPX5 and is connected to a HB41 handset with a DIN plug.
CS32 B is also available in IPX6.
- The CS32 C is standard IPX1 and is connected to an external contact or control. **See Figure 6.7.**

Mechanical spline:

The splines function so that the actuator can only push, not pull.

During pull in the actuator, the inner tube is lifted off the thread bush, and the actuator can therefore never pull a load, only push. **See figure 8.**

Functional test of mechanical splines:

When the piston rod is at the innermost position, it must be possible to pull it out manually to its full travel length and to press it in again without much resistance and without using the motor. If this is not possible, contact your nearest LINAK dealer.

Electrical splines:

In the rear fixture on the actuator, a microswitch is fitted, which turns off the motor, if the actuator is exposed to pull forces.

Functional test of electrical splines

When the actuator is correctly fixed/mounted, the inward movement of the piston must stop, when the actuator is pulled or the movement is blocked, so that the back fixture is not put under undue stress/tension. For mounting, see **Figure 7**.

Quick release

When the quick release arm, **see Figure 9**, is turned counter clockwise approx. 75° and fixed here, the piston rod is released and can now be pressed in to its innermost position or pulled out to its outermost position.

When the quick release arm is released, the arm turns back and the actuator functions normally again. The piston rod must not be tight.



Warning!

- If the actuator does not work as described above, the risk of injury due to squeezing can arise. Therefore the actuator must immediately be sent for service at the nearest, authorised LINAK workshop.
- The actuator must not be used in pull applications when the quick release is activated, as the risk of personal injury can arise.
- Do only use the actuator within specified working limits.

9. LA34 (MEDLINE® TECHLINE™)



The LA34 actuator is a technological state-of-the-art actuator that, due to its innovative construction can push up to 10,000N at a speed of 5 mm/sec. and with a power consumption of approx. 7 Amp.

Its compact design, the outstanding performance and a wide range of safety options makes LA34 the right choice for a variety of medical and industrial applications.

Reed-switch:

The Reed-switch gives a number of pulses for each rotation of the motor. These pulses are used to calculate the piston rod's position as well as to control several actuators running in parallel.

Your nearest LINAK dealer can inform the number of pulses per stroke length.

Regarding Reed-switch connection, **see Figure 6.10**.

If the LA34 actuator is used in connection with a non-LINAK power supply the system must be equipped with current trip cut-off.

Adjustment of the installation dimension N

As standard the installation dimension on the LA34 actuator can be manually adjusted by +4/-0 mm (not possible for mechanical splines). The adjustment of the installation dimension must only be made without use of tools only, or hand). It is not allowed to use tools to adjust the installation dimension of the LA34 actuator as there is a risk that the inner tube may be unscrewed.

Hall

The Hall principle is very similar to the Reed principle. It is a control box, which based on Hall signals, can decide whether the actuator runs out or in. Hall, however, can detect whether the actuator runs in or out. The number of pulses is like Reed. Hall and Reed are placed opposite the potentiometer on the actuator's worm wheel. Therefore, it is not suitable for use in quick release /free wheeling actuators. **see figure 10**.

Potentiometer

The potentiometer function is mechanically attached to the spindle and registers the number of spindle

revolutions. The signal from the potentiometer is measured in Ohm, where the lowest value is measured when the actuator has been run into inward switch stop. The potentiometer is a 10-turn and therefore it is dependent on the stroke length/spindle pitch. **see figure 6.5**

Mechanical spline:

The splines function so that the actuator can only push, not pull.

During pull in the actuator, the inner tube is lifted off the thread bush, and the actuator can therefore never pull a load, only push. See **Figure 8**.

Functional test of mechanical splines:

When the piston rod is at the innermost position, it must be possible to pull it out manually to its full travel length and to press it in again without much resistance and without using the motor. If this is not possible, contact your nearest LINAK dealer.

Electrical splines:

In the rear fixture on the actuator, a microswitch is fitted, which turns off the motor, if the actuator is exposed to pull forces.

Functional test of electrical splines

It is important that the actuator is correctly fixed with regard to the section on page 11. For mounting, see **Figure 7**.

When the actuator is correctly fixed/mounted, the inward movement of the piston must stop, when the actuator is pulled or the movement is blocked, so that the back fixture is not put under undue stress/tension.

Quick Release

LA34 (34xxxF/H) is equipped with a function which permits operation of the actuator should the power source fail. Condition for functioning: the actuator must be loaded in push direction (LA34xxxF) or pull direction (LA34xxxH).



Warning!

- If the actuator does not work as described above, the risk of injury due to squeezing can arise. Therefore, the actuator must be sent immediately for service at the nearest, authorised LINAK workshop.
- The actuator must not be used in pull applications when the Quick Release is activated, as the risk of personal injury can arise.
- Do only use the actuator within specified working limits.

Activation of Quick Release

Pull the release handle in the direction of the piston rod eye (outwards), the harder you pull the button the quicker the actuator runs down. When releasing the button the emergency lowering stops immediately. The emergency lowering is activated as long as the load on the actuator is above 100-150 kg. The actuator is ready for normal use when the emergency lowering is finished.

Safety device regarding functional failure of the nut (Safety nut):

The LA34 has a built-in safety nut in push as standard and is available with a safety nut in pull as an option. Actuators with safety nut in push can only function when used in push applications. The safety nut comes into operation should the main nut fail. Afterwards it is only possible to drive the actuator into the innermost position. Safety nut in pull is for pull applications and works the opposite way as described above. Thereafter, the actuator will not function any more and must be sent for service.

Built-in end-stop circuit

In the actuators mentioned the end-stop switch is part of the actuator construction. Each time the actuator reaches end-stop position, the switch is activated and the current is cut off.

10. LA44 (MEDLINE® CARELINE®)

LINAK®
WE IMPROVE YOUR LIFE

Item No. : 442104+5L3001A0
 Prod. Date : 2009.03.18 S.O.7654321
 Max Load : Push 12000 N IPX4
 Power Rate : 24 V= / Max. 9.5 Amp
 Duty Cycle : 10%, Max. 2 min. / 18 min.
 NOT TO BE OPENED BY UNAUTHORIZED PERSONNEL

CE N576

P.O.123456-0001 MADE BY LINAK A/S DENMARK

The LA44 is a technological state-of-the-art actuator with a refreshing new design, that due to its innovative contraction, can push up to 12000N at a speed of 5 mm/sec. (24V DC). Its compact design and outstanding performance makes the LA44 the right choice for patient lifts and a future variety of medical and industrial applications. The LA44 complies with the increased requirements (e.g. load and no. of cycles) of the latest revision of EN ISO 10535:2006.

Built-in end-stop switches

The end-stop switch is part of the actuator construction. Each time the actuator reaches end-stop position, the switch is activated and the current is cut off.

Mechanical Spline

The Spline functions so that the actuator can only push, not pull.

Precautions:

- Power supply without current cut-off can cause serious damage to the actuator if a mechanical stop is encountered or the actuator movement is blocked in another way.
- If there is a risk of “pull forces” in the application, the actuator must be equipped with mechanical or El-spline to avoid damage in pull.

Manual lowering:



Fig. 1. Manual Lowering

In case of a power failure it is possible to mechanically lower a patient placed in a patient lift. When turning the manual lowering handle clockwise the actuator can be moved fully inwards.

Fitting the plug/smart cable lock



Fig. 1

Step 1:



Fig. 2

Step 2:
Position and press the cable plug into the socket.



Fig. 3

Step 3:

Unlocking the plug/smart cable lock

Flanges in locked position
Press here with tool

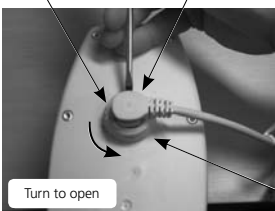

Fig. 1

No tap on this side

Unlocking the cable lock

Using a tool, release the lock (must be from the side shown) by pushing the tap (through the small slot in the side of the lock).

At the same time, turn the lock counter-clockwise to release the plug connection.

Warnings!

- The actuator must not be subject to a sideways load, as this can cause bending. It is also for this reason that the actuator should not be used as a handle.
- The actuator must not be subject to moment loading, as this can damage the actuator.
- The actuator must not be subject to impact or blows, or any other form of stress to the casing.
- The actuator must not be subject to overload, as this can reduce the lifetime of the actuator and in the worst case cause damage to the actuator.
- The LA44 must not be used in pull applications, as this can cause collapse.
- Do not hold the inner or outer tubes when the actuator is running due to danger of squeezing.
- Do only use the actuator within specified working limits.



Recommendations

- It is recommended that the actuator is serviced according to the relevant national norms for the applications in which the actuator is used.
- Connection bolts must be dimensioned so that they have the necessary strength in order to obtain the minimum safety factor according to the requirements of the authorities.
- Connection bolts and brackets are to be inspected in connection with service, and must be replaced if there are signs of wear and tear.
- The safety function: Electrical Spline, should be checked in connection with service. The function is checked by applying a straight pull, of max. 100 N, to the back fixture. The actuator must not be able to run in an inward direction. Hereafter press the back fixture against the housing and the actuator can run in an inward direction.
- The actuator should be cleaned regularly, in order to maintain a good hygiene.
- Inspect the actuator minimum once a year for wear and jarring sound

4. Information on specific columns :

1. BB3 (MEDLINE® CARELINE®)

LINAK®
WE IMPROVE YOUR LIFE

Item No. : BB3610A03400345
Prod. Date : 2009.03.18 S.O.7654321
Max Load : Push 1600 N IP00
Power Rate: 24 V= / Max. 3.5 Amp
Duty Cycle : 10%, Max. 2 min. / 18 min.
NOT TO BE OPENED BY UNAUTHORIZED PERSONNEL

CE N576

P.O.123456-0001 MADE BY LINAK A/S DENMARK

The BB3 3-part telescopic actuator is the ideal choice for vertical lift of beds where design and easy integration in the customer's guidance ensures optimum freedom of design.

The BB3 is a 3-part telescopic actuator designed to meet EN 1970 for care beds, which demands an adjustment range from 350 mm up to 750 mm.

Reed-switch:

The Reed-switch gives a number of pulses for each rotation of the motor. These pulses are used to calculate the piston rod's position as well as to control several actuators running in parallel.

Your nearest LINAK dealer can inform you of the number of pulses per stroke length.

Regarding reed-switch connection, **see Figure 6.10.**

- The columns must be securely mounted before operation, no rotation must be possible
- The motor housing must be mounted uppermost.



Warning:

Do only use the column within specified working limits.

2. BL1 (MEDLINE® CARELINE®)

LINAK®
WE IMPROVE YOUR LIFE

Item No. : BL1411A01400A
Prod. Date : 2009.03.18 S.O.7654321
Max Load : Push 2000 N IPX6
Power Rate: 24 V= / Max. 4.8 Amp
Duty Cycle : 10%, Max. 2 min. / 18 min.
NOT TO BE OPENED BY UNAUTHORIZED PERSONNEL

CE N576

P.O.123456-0001 MADE BY LINAK A/S DENMARK

The BL1 is a 3-part lifting column specially designed for hospital and care beds; the BL1 can of course be used for other applications where a compact lifting column with a long stroke length is needed. The lifting column has an build-in open spindle actuator with a chain drive which is practically noiseless. The specifications comply with the demands to the lifting functions in beds as to load, speed and stroke length.



Warning:

Do only use the column within specified working limits.

3. BL4 (MEDLINE® CARELINE®)

LINAK®
WE IMPROVE YOUR LIFE

Item No. : BL1411A01400A
Prod. Date : 2009.03.18 S.O.7654321
Max Load : Push 1500 N IPX4
Power Rate: 24 V= / Max. 4 Amp
Duty Cycle : 10%, Max. 2 min. / 18 min.
NOT TO BE OPENED BY UNAUTHORIZED PERSONNEL

CE N576

P.O.123456-0001 MADE BY LINAK A/S DENMARK

The BL4 is a 4-part lifting column specially designed for hospital and care beds; the BL4 can of course be used for other applications where a compact lifting column with a long stroke length is needed.

The lifting column is based on the BB3 actuator, which is practically noiseless. The specifications comply with the demands to the lifting functions in beds as to load, speed and stroke length.

Reed-switch:

Reed-switch gives a number of pulses for each rotation of the motor. These pulses are used to calculate the piston rod's position as well as to control several actuators running in parallel.

Your nearest LINAK dealer can inform the number of pulses per stroke length.

Regarding Reed-switch connection, **see Figure 6.10.**

- There are mounting holes in the endplates and motor housing

- The columns must be securely mounted before operation, no rotation must be possible
- The motor housing must be mounted uppermost
- The mounting bracket tension must be adjusted correctly



Warning:

Do only use the column within specified working limits.

4. LC2 (MEDLINE® CARELINE® TECHLINE™)



The LC2 column is an update of the LP2 programme. It has an improved “twisting” stability and end-stop switches as standard.

The column is designed to be used in a vertical position and only for lifting purposes. It is not possible to use the column in any kind of “pull” application.

Depending on the application, the LC2 can be operated either as a single column or several columns in a parallel system by choosing a control box with microprocessor.

It is designed to provide vertical lifting (push only) where simultaneous bending and torsion moments may occur.



Warning:

Do only use the column within specified working limits.

5. LP2 (MEDLINE® CARELINE® TECHLINE™)

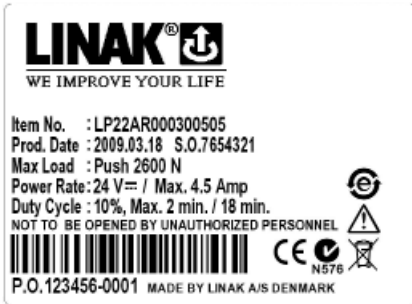

The LP2 range of vertical lifting columns is ideal where vertical positioning of substantial loads is required.

The design allows the LP2 range to be built in a complete motion control system simply by adding a suitable LINAK control box and handset.

Advanced design and high quality construction allows the column to be operated either as single or parallel with up to a maximum of four units and/or with a memory function.

The LP2 lifting column is the ideal choice for duties such as height adjustment on computer workstations, work benches, or a wide selection of other duties.

- There are mounting holes in the end plates.
- The largest profile must be mounted uppermost.



Warning:

Do only use the column within specified working limits.

6. LP3 (MEDLINE® CARELINE® TECHLINE™)



The LP3 is developed for vertical lifts and can resist a bending moment by virtue of the effective telescopic system.

The lifting column is designed for applications where a small installation dimension is requested without compromising the lifting capacity.

The LP3 is characterised by having a lower installation dimension proportional to the stroke length compared to the LP2. The LP3 can also attain a higher speed than the LP2.

The telescopic column is compatible with LINAK's control boxes and can run individually; as 2 x LP3 parallel and/or with memory.

The LP3 is the perfect choice for height adjustment on dental, gynaecologist, and wheelchairs as well as for operating, office and working benches etc.



The column can only be loaded with the maximum bending moment over the first 80% of the stroke. The maximum bending moment will be reduced to 50%.



The column must be mounted with the largest profile uppermost!

- There are mounting holes in the end plates.
- The largest profile must be mounted uppermost.



Warning:

Do only use the column within specified working limits.

5. Information on specific control boxes:

Please be aware if the control box is not visible after mounting, all information regarding limitation of use shall be marked on the end product.

Output voltage

On control boxes connected to the mains the voltage of the actuator output is dependent on load, and the no-load voltage can reach 50 V. Control boxes connected to a battery can reach a voltage of 30 V during charging and no load.

For all control boxes with battery

Prior to first use of LINAK batteries, please make sure that they are being charged 24 hours in order to reach proper function and prolong the lifetime of the batteries.



Warning!

Please observe the following maintenance, replacement, and disposal requirements to ensure a safe and reliable operation.

Maintenance of batteries

The batteries are to be replaced after 4 years at the latest. Perhaps earlier, dependent on the pattern of use. Frequent and high-powered discharges reduce the battery life. For an optimum lifetime the product must be connected to the mains voltage as often as possible. The batteries must be charged at least every 3rd month - otherwise they will be damaged in due to self-discharge. It is recommended to test the battery function at least once every year.

Replacement of batteries

The batteries must only be replaced by the same type of batteries or mechanical and electrical equivalent types.

The batteries must be new or maintained by means of charging at least every 3rd month. The batteries, which make a set, must be supplied with identical production codes. Mismatching of production codes may lead to a severely reduced life time expectancy.

Before mounting ensure that the battery set is correctly connected, compare with the drawing in the battery room, and check that no connectors are loose.



Warnings!

From the factory the battery room is hermetically separated from the electronics room. When replacing the batteries this separation must not be damaged or modified as this may allow penetration of battery gas into the electronics room with risk of explosion.

When replacing batteries in waterproof products (IPX5 and IPX6) precautions must be taken that the sealing material (silicone ring or joint filler) is not damaged and that it is correctly placed in the groove. Hereafter the screws in the cover are to be fastened with approx. 1 Nm. If the seal is damaged it must be replaced by a new silicone string (LINAK article no. 0008004 for a roll of 100 metres).

Disposal

The batteries, which are lead-acid batteries, can be returned to LINAK or disposed in the same way as car batteries.



Warnings!

The battery room is supplied with ventilation that ensures correct and necessary airing of the battery room. This airing must not be blocked or covered as a positive pressure may occur with risk of explosion.

If the product has been exposed to mechanical overload (lost on the floor, collision/squeezing in the application or a powerful stroke) the product must be sent to an authorised workshop for control of the hermetic separation between the battery and electronics rooms.

1. CB6 (HOMELINE®)



The CB6 control box has been specially developed for use together with LA27 actuator in the care and rehab industry.

The control box is designed to be mounted on the actuator LA27 as with the CB9 and LA31 system.

The CB6 control box has a LED power ON indicator, detachable mains cable and strain relief for all cables.

The control box CB6 communicates with the LA27 actuator by means of the built-in end stop signal switches in the actuator. Due to the signal switches the power to the motor will be cut off in the control box and not in the actuator.

This ensures that it is only possible to run in the opposite direction once the actuator has reached the end position.

2. CB6S (CARELINE®)

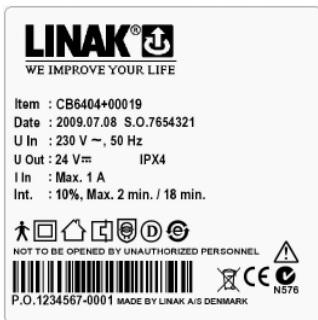

CB6S is part of the LINAK OpenBus™ product range – that provides more flexible solutions no matter which actuator concept is preferred. LA27C, LA31, LA34, BL1, BL4 with mini-fit plug and std. end-stop switch/signal switch are all supported. Please be aware the actuators must be used within their current limits in order to maintain proper use and full compatibility within a system.

Three versions are offered:

CB6 OBL, CB6 OBM and CB6 OBF

(OBL = OpenBus Light; which is RELAY based and OBF = OpenBus Full which is FET based).

(OBM = OpenBus Medium; which is RELAY based

Microprocessor

All control boxes with a microprocessor must be initialised before start-up. A description of the initialisation procedure can be obtained from your LINAK dealer.

If an actuator is replaced, the micro-processor always has to be initialised before use (actuators with reed/hall).

If re-programmed, please ensure that the correct software is used.

3. CB7 (CARELINE® TECHLINE™ HOMELINE®)

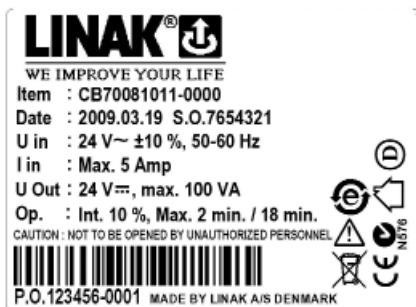

Compared to other LINAK control boxes the CB7 is very small and compact in design.

The CB7 is designed to slide onto an LA31 actuator for easy fitting e.g. in a recliner application where "mounting" space is limited.

The control box function is divided in two parts. The actual control box CB7, which slides onto the LA31 actuator and a separate external power supply transformer box TR6 or TR7, which can be wall mounted or placed on the floor moulding next to the mains.

The control box is only fitted with low voltage electronic components and the connection between the CB7 and transformer is via a 24 V power cable.

4. CB8-A (CARELINE® TECHLINE™)



The CB8-A is a battery powered control box operating up to 3 actuators individually. One of these channels can be used either as an emergency stop or for battery charging.

Simple design and high quality construction make the CB8-A an ideal control box choice for mains-free operation of beds, chairs, tables, and many other mobile applications.

5. CB8-T (TECHLINE™)



The CB8-T is developed for use with LINAK A/S' actuators and handsets. The control box can operate up to 2 actuators individually.

The simple compact design combined with high quality makes the control box ideal for use with beds, chairs, tables, and many other applications.

6. CB9 (MEDLINE® CARELINE® HOMELINE®)



The CB9 has been developed for use in the Care & Rehab industry. The CB9 and the LA31 can be fully integrated, which saves mounting and wiring or be installed separately. The CARELINE® CB9 series is available as either analogue (Ax) or μ -processor based (Px) types.

CB9PF with mains cut-off

In standby mode the CB9PF with mains cut-off will typically switch off the power supply to the transformer for 3-4 hours, following which it will switch on the mains supply for approx. 3 sec. It will then be switched off again for 3-4 hours. If the control box has an internal/external battery, the power supply to the transformer will not be switched off until the battery is fully charged.

CB9 with mains cut-off

After 4-5 days with the mains connected, but without activating any functions, it may be necessary to switch off the mains for a couple of minutes, and then switch it on again. Each time the mains is switched off/on this period resets.

The unique feature of the mains cut-off is that it can also be switched on in building installations where, for example, the meter cupboard contains an electronic circuit which switches off the mains. The mains cut-off in the meter cupboard monitors the power consumption and disconnects the power supply when consumption is below a certain minimum. In such installations the CB9's own mains cut-off can typically be activated 4-5 days after the last activation. If this period is exceeded, the mains will have to be started by another load, e.g. a lamp, to charge the capacitor in the control box, following which the control box can be activated.

Microprocessor

All control boxes with a microprocessor must be initialised before start-up. A description of the initialisation procedure can be obtained from your LINAK dealer.

If an actuator is replaced, the micro-processor always has to be initialised before use (actuators with reed/hall).

If re-programmed, please ensure that the correct software is used.

External battery charger

If anything other than a LINAK® charger is used, it must conform to the following specifications: Charging voltage: 27.6 VDC \pm 2% Charging current: < 300 mA.

7. CB12 (MEDLINE®)



The CB12 product range features three standard versions, which are ideal for a vast number of medical and industrial applications.

In general the CB12 is a transformer operated control unit, which can control up to 4 actuators. The control box features a range of built-in safety devices, increased current cut-off, EAS (Electronic Arc Suppression), and other options such as battery backup, earth outlet, wet alarm etc.

CB12F with mains cut-off

In standby mode the CB12F with mains cut-off will typically switch off the power supply to the transformer for 3-4 hours, following which it will switch on the mains supply for approx. 3 sec. It will then be switched off again for 3-4 hours. If the control box has an internal/external battery, the power supply to the transformer will not be switched off until the battery is fully charged.

External battery charger

If anything other than a LINAK® charger is used, it must conform to the following specifications: Charging voltage: 27.6 VDC \pm 2% Charging current: < 300 mA

8. CB14 (MEDLINE® TECHLINE™)



The CB14 with microprocessor is developed for systems with a need to run up to five actuators or two actuators / lifting columns in parallel and / or with memory function.

The effective toroidal transformer and the many features such as battery backup, earth outlet, wet alarm makes the control box suitable for a variety of applications.

Memory position on CB14

When storing the memory position on CB14 the actuators must be run to the wanted position and the "store" button (S) must be pushed. Hereafter, the selected memory button (1, 2, or 3) must be activated within 2 seconds.

Microprocessor

All control boxes with a microprocessor must be initialized before start-up. A description of the initialisation procedure can be obtained from your LINAK dealer. If an actuator is replaced, the microprocessor always has to be initialised before use (actuators with reed/hall).

If re-programmed, please ensure that the correct software is used.

External battery charger

If anything other than a LINAK® charger is used, it must conform to the following specifications: Charging voltage: 27.6 VDC \pm 2% Charging current: < 300 mA.

9. CB16 (MEDLINE®)



CB16 is part of the LINAK OpenBus™ product range – that provides more flexible solutions no matter which actuator concept is preferred. LA27C, LA31, LA34, BL1, BL4 with mini-fit plug and standard end-stop switch / signal switch are all supported. Please be aware the actuators must be used within their current limits in order to maintain proper use and full compatibility within a system.

Two versions are offered:

CB16 OBL and CB16 OBF

(OBL = OpenBus Light; which is RELAY based and OBF = OpenBus Full which is FET based).

Microprocessor

All control boxes with a microprocessor must be initialised before start-up. A description of the initialisation procedure can be obtained from your LINAK dealer.

If an actuator is replaced, the micro-processor always has to be initialised before use (actuators with reed/hall).

If re-programmed, please ensure that the correct software is used.

10. CB20 (MEDLINE®)

The CB20 is the platform for the future with a unique safety concept, logging of service data and it is possible to connect a variety of accessories to the control box.

The CB20 consists of 3 modules :

CP20 = Control Power, CU20 = Control Unit and BA20 = Battery.

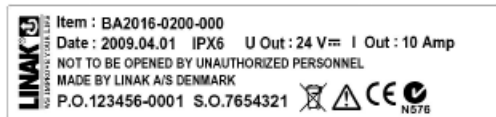
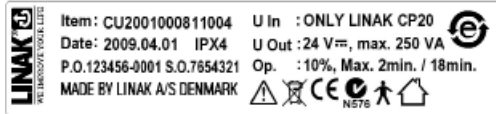

To ensure the battery pack BA20 has max. efficiency the following must be complied with:

- The battery pack BA20 must be connected
- Mains voltage must be connected min. 12 hours before use.

Microprocessor

All control boxes with a microprocessor must be initialized before start-up. A description of the initialization procedure can be obtained from your LINAK dealer. If an actuator is replaced, the microprocessor always has to be initialized before use (actuators with reed/hall).

If re-programmed, please ensure that the correct software is used.

External battery charger

If anything other than a LINAK® charger is used, it must conform to the following specifications: Charging voltage: 27.6 VDC ± 2% Charging current: < 300 mA.

11. CBR1 (MEDLINE® CARELINE® HOMELINE®)



The CBR1 has been developed for use together with the RA40 Rotary actuator. The CBR1 can be installed in the same profile as the RA40 Rotary actuator thus saving mounting and wiring.

6. Information on specific controls:

1. ACC (MEDLINE® CARELINE® OpenBus)



The ACC (Attendant Control Compact) is fitted to advanced hospital and patient care beds for use where patient positioning must be carefully controlled by medical staff.

2. ACK (MEDLINE® CARELINE®)



The OpenBus™ system makes it possible to use keypads as Attendant Controls or Handsets integrated in the bed side rails. The keypads are named ACK (Attendant Control Keypads).

The protection class is dependent on customer design and testing.

3. ACL (CARELINE®)

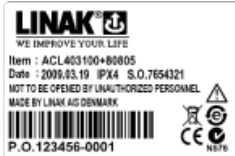

The ACL (Attendant Control Lock) box is a one turn button box fitted to hospital and care beds for use where the patient positioning must be carefully controlled by the medical staff.

The ACL disconnects all functions on some handsets.

4. ACM (CARELINE®)

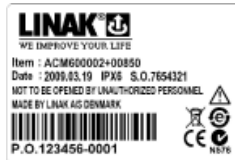

The ACM (Mini Attendant Control) box is fitted to hospital and care beds for use where patient positioning must be carefully controlled by the medical staff.

The compact design and simple operation makes it easy for the nursing staff to retain direct control over critical positioning functions whilst giving the patient a limited degree of adjustment.

5. ACP (CARELINE®)

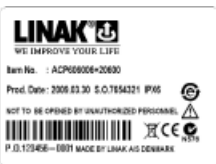

The ACP (Attendant Control Panel) controller is fitted to advanced hospital and patient care beds for use where patient positioning must be carefully controlled by medical staff.

The ACP allows nursing staff to retain direct control over critical positioning functions while giving the patient a limited degree of adjustment.

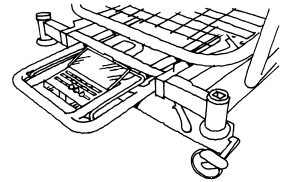

6. ACO (MEDLINE® CARELINE® OpenBus)



The ACO (Attendant Control OpenBus) is a cost optimised and compact unit with up to 15 buttons that can be used as Handset keys or lock-outs.

The lock-out function can be made visible by using yellow LED's.

The ACO is compatible with control boxes that use an OpenBus™ interface i.e. CB65, CB16 and CB20.

7. FPP (CARELINE®)



The FPP (Flexible Patient Panel) is a user-friendly control panel especially for elderly people or disabled persons, placed on a flexible arm to be mounted on the bed frame in front of the patients head.

The FPP makes the patient more independent, is ergonomically designed by the users and easy to install on even the most advanced equipment.

The FPP has a flexible arm which makes it immediately available by simply pulling and bending it into position. When not in use the patient can also push it slightly away. However it is never dropped or lost on the floor.

The FPP is for use with a variety of different bed types and is therefore compatible with control boxes that use an OpenBus™ interface i.e. CB6S, CB16 and CB20.

8. FS (MEDLINE® CARELINE®)



The Foot Switch is a modular system, developed for use together with some of LINAK control boxes.

The LINAK Foot Switch is designed for control of physiotherapeutic beds, hospital beds, dentist chairs, gynaecologist chairs, computer workstations, and working desks etc. It can also be used as a "stand alone" item for industrial applications.

Footswitch

Consist of: FS (a pedal unit) and FSE (electronics unit), which can activate one or more actuators. The module system can max. consist of two pedal units, a FSR (right pedal), a FSL (left pedal), and one electronics box.

9. FS2 (MEDLINE® CARELINE®)



The FS2 Foot Switch is developed for use together with some of LINAK control boxes and especially designed for mounting on a support plate.

The Foot Switch is available in a single and a double version.

The double version can be used on a bed where one Foot Switch will be mounted on each side of the bed frame, thus enabling operation from both sides.

10. HB20 (MEDLINE® CARELINE® HOMELINE®)



The HB20 series combines ergonomic design with a wide range of functionalities such as memory and infrared communication. The handset series is compatible, via the IRO, with the OpenBus™ product assortment.

11. HB40 (MEDLINE® CARELINE® TECHLINE™ HOMELINE®)



The HB40 series handsets are designed for use with most of LINAK control boxes.

These sturdy compact units are ergonomically designed and ideal for a vast range of applications from patient care beds and office furniture to industrial and agricultural duties.

12 HB50 (MEDLINE® CARELINE® TECHLINE™)



The HB50 is primarily designed for the LINAK JUMBO system and most of LINAK control boxes with memory functions.

The HB50 gives the user access to a range of memory functions, allowing present positions to be stored. For use in a wide variety of hospital, patient care and industrial applications.

13. HB60 (MEDLINE® CARELINE® HOMELINE®)



The HB60 series is exclusively designed to be used together with the LINAK HOMELINE® system: LA31/LA29/LA28/CB7 or CB9 with or without memory.

14. HB70 (MEDLINE® CARELINE® TECHLINE™)



LINAK offers the HB70 with protection class IPX6 as standard and a range of options such as control of up to 5 actuators, memory, and simultaneous drive. The HB70 is designed to operate with most LINAK control boxes.

15. HB80 (MEDLINE® CARELINE®)



The HB80 is a new handset with an optimised ergonomic design and switch activation.

The HB80 handset is designed in 2 versions.

The HB80 must hang vertically from its hook during the washing process.

16. HL70 (MEDLINE® CARELINE®)



The HL70 is a handset with integrated locking function, where a selective locking of the different functions is available by use of a special key. The HL70 is an alternative to the HB70 combined with an attendant Control Panel (ACM, ACL, etc.).

17. HL80 (CARELINE®)

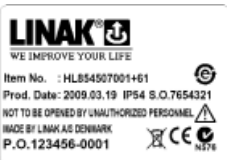

The HL80 is a new handset with an optimised ergonomic design and switch activations.

The HL80 is a lockable handset, which makes it possible to lock or unlock one or several functions.

Warnings and Recommendation for HL80, HB80 and HD80



Warnings!

- Clean the handset regularly to ensure good hygiene standards.
- When a defective Hx80 is replaced, check that the new Hx80 has exactly the same specification and functionality.

- Violent use of the key on HL80 can cause either damage to the keyhole or the key itself.
- When using the locking function on HL80 check that the handset switches are actually locked.
- Locking function on HL80 only locks the actual handset.
- Do not submerge the handset under water - except IPx7.
- Unless otherwise specified or agreed by LINAK - the Handset is only intended to be used on LINAK systems.
- Do not sit or lie on the handset. It can cause unintended movement of the bed.
- When changing handsets for OpenBus™ - the power must be switched off.
- If handsets with magnet are hooked on a slim surface, a movement or oscillation of the cable, for example during a transport, can cause the handset to move and result in damage if the cable is getting squeezed somewhere.
- The force of the magnet depends on thickness of the lacquering, the lacquering type, stickers, steel thickness etc. It is the responsibility of the customer to verify that the holding force on the application is acceptable.
- For handsets with magnet hook: It is the responsibility of the user/operator to evaluate any possible risk caused by use of permanent magnets.



Recommendation

- It is recommended to check the handset and cable for damage and holes made by violent handling before washing the bed, or at least once a year.
- For handsets with magnet it is recommended to have a parking place for the handset in the application, where customer ensures that the handset does not fall off.

18. IRO (MEDLINE® CARELINE®)

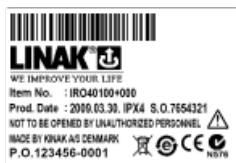

The IRO (Infrared Receiver OpenBus™) has been developed as a part of the accessory portfolio to be available for the CB OpenBus™ family. The receiver is fitted to the bed so that the bed movement can be controlled with signals received from a remote control (C-type Transmitter).

19. LS (TECHLINE™)

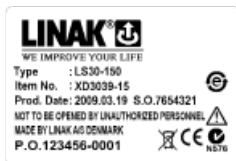

There are two types of LINAK limit switches, for actuators type LA22, LA30, LA30S, LS, and LSD.

The LS type gives a signal in two fixed end positions, but requires a control unit to stop the actuator when the microswitches are activated.

20. LSD (TECHLINE™)



The LSD type controls the stroke length of the actuator between two fixed end positions by cutting off the current to the motor.

7. Information on specific JUMBO :

1. BAJ1 (MEDLINE® CARELINE®)



These battery packs have been specially developed for use with the JUMBO system.

The battery packs are easy to exchange through an integrated snap system.

The battery packs are easily mounted on the JUMBO mounting brackets.

A customised front cover is possible.

The BAJ1 has to be charged with a JUMBO charger CHJ2 or a JUMBO control box CBJ1 or CBJ2 with integrated charger.

The BAJ1 is ventilated through a breather hole on the backside of the housing.

2. BAJ2 (MEDLINE® CARELINE®)



These battery packs have been specially developed for use with the JUMBO system.

The battery packs are easy to exchange through an integrated snap system.

The battery packs are easily mounted on the JUMBO mounting brackets.

A customised front cover is possible.

The BAJ2 can be charged as the BAJ1, but can also be charged through an integrated DC-plug for use with charger CH08.

The BAJ2 is ventilated through a breather hole on the backside of the housing.

3. CBJ1/CBJ2 (MEDLINE® CARELINE®)

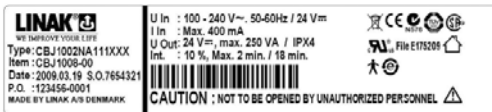

The control boxes CBJ1 and CBJ2 are part of the JUMBO system. JUMBO is a modular system combining an actuator, a control box (CBJ1/CBJ2), a battery (BAJ1/BAJ2), and a charger (CHJ2) in a flexible solution, specially developed for patient lifts.

The complete system is medically approved and contains a series of features, which meet the patients need for a safe and comfortable lift, e.g. CBJ1 and CBJ2 are equipped with a soft-start/stop function, emergency lowering function etc.

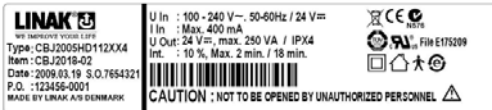

Mounting of CBJ1 and CBJ2:

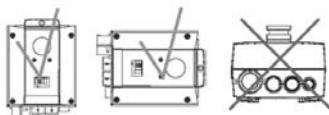

The CBJ1 and CBJ2 with internal chargers are **IPx4** when **the shaver plug is connected**.

4. CBJC (MEDLINE® CARELINE®)

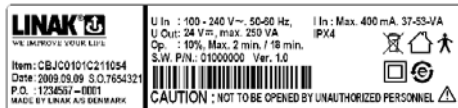

The control boxes CBJC is a part of the JUMBO system. JUMBO is a modular system combining an actuator, a control box (CBJC/CBJ1/CBJ2), a battery (BAJ1/BAJ2), and a charger (CHJ2)/internal charger in a flexible solution, specially developed for patient lifts.

The complete system will be medically approved and contains a series of features, which meet the patients need for a safe and comfortable lift, e.g. CBJC is equipped with a soft-start/stop function, emergency lowering function, learn mode for current cut off, service indicator and battery indicators. Furthermore usage information is collected in the control box.

CBJC has to be mounted vertically to ensure the IP protection



Notifications:

- As standard the service indicator will blink every 12 months/after 8000 Cycles (whichever comes first). Other service intervals can be programmed.
- When one continues to use the application at the lowest battery level the diode will blink and start giving an audio signal. At that time it will be possible to drive channel 1 (lifting arm) down (but not up and leg spread is not possible).
- It is not possible to use other battery types than (BAJ1/BAJ2) with the Jumbo Care.
- The green battery indicator (100% to 50% capacity remaining) will light up during charging even though the battery is not fully charged.
- The current cut off registration function can only be activated by using a specially produced handset (HB7x235-00). A standard handset cannot activate the function.
- The maximum cut-off value that can be registered (stored) is 11 ±1.0 Amp.
- If an actuator or CBJC is exchanged it will be necessary to reset the max. load to ensure the correct cut-off value for the new system as a whole.
- Resetting of service is done by pressing 2 buttons (lifting arm up/down on standard LINAK hand controls) on the hand control at the same time for 5 seconds. After pressing the buttons for 5 seconds you will receive an audio signal indicating that the timer is reset. The timer will reset the diode.

5. CBJH (MEDLINE® CARELINE®)



The CBJH-HOME is a specially developed solution for patient lifts. The complete system consists of a control box and a battery enclosed in a single elegant module.

The system will be medically approved and contains a series of features ensuring a safe comfortable lift, e.g. the CBJH-HOME is equipped with a soft-start function, emergency lowering, emergency stop etc. The CBJH-batteries are ventilated through a number of grill units on the backside of the housing.

Replacement of battery:

Only an authorised LINAK service centre should change a battery in a CBJH. If a CBJH is opened and a battery changed by an unauthorised personel there is a risk that it may malfunction at a later date.

Mounting of CBJH (only vertically)



6. COBO20 (MEDLINE®)

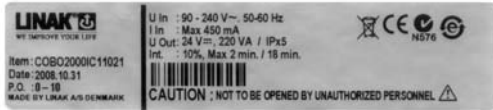

The COBO20 makes increased battery power available (compared to BA20). It is designed to be used with CU20 together with BAJ1 or BAJ2 (12V, 2.9 AH). It is also possible to use other battery types.

COBO20 with internal charger has a green and a yellow light. Green is ON when the COBO20 is connected to mains and the yellow is ON when charging. The yellow light shines constantly until the batteries are fully charged.

The COBO20 has an EMC approval.

Mounting of COBO20:

- COBO20 as to be mounted vertically to insure the IP protection
- The cable from COBO20 has to be mounted into the power input at CU20



Recommendations:

- If own battery package is used, a10A fuse must be added.
- It is recommended that the COBO20 is serviced according to the relevant national norms for the applications in which it is used, however all electrical parts must be checked at least once a year.
- The COBO20 should be cleaned regularly, in order to maintain good hygiene. It is not allowed to use chemicals to clean the box.
- Choose CU200xxxxx2xxxx if positioning/memory is to be used.
- **Only** use COBO20 together with CU20.
- After activation of emergency stop it can take up to 10 seconds before the system can be used again.

7. CH01 (MEDLINE® CARELINE®)

For charging the batteries of CB08-XA and all JUMBO control boxes, directly connected to the control box or via the handset HB40A.

For charging of the batteries in battery box BAJ2 (JUMBO system) and CBJH.

8. CH08 (MEDLINE®)

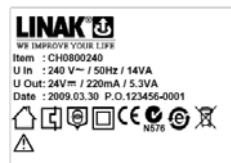

For charging of the batteries in the control box CB08-A, directly connected to the control box or via the handset HB40A.

For charging of the batteries in battery box BAJ2 (JUMBO system) and CBJH.

LINAK's product range covers several chargers. The CH08 can be used for the CBJH and CB8-A.

9. CHJ2 (MEDLINE® CARELINE®)

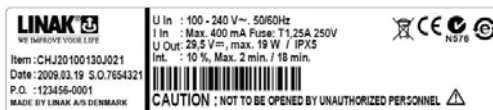

The charger CHJ2 has been specially designed for use as a wall-charger for the JUMBO system. The CHJ2 charger is a Switch Mode Power Supply (SMPS) version, which makes charging of the batteries more efficient.

The charging time for a BAJ1 or a BAJ2 battery pack is approx. 4 hours.

Mains voltage from 100 V AC - 240 V AC (50/60 Hz) is possible on same charger.

10. MBJ1/2/3 (MEDLINE® CARELINE®)

Depending on of what your JUMBO system consists you need to use one of the following three mounting brackets. IP protection is only valid when the JUMBO system is mounted vertically.

8. Information on specific accessories :

If the actuator is to be equipped with accessories, these must be specified when ordering the actuator from LINAK. There are the following possibilities:

1) TR6/TR7 External transformer

If the TR6 or TR7 fixed cable connection becomes damaged the transformer must be replaced.

1. BA18 (MEDLINE® CARELINE®)



Compatible with CB9, CB18-AT-version, CB12 BT version, and CB14 BT version.

The BA18 is exchangeable without opening the CB (BA18 is a separate box).

Ventilation of external batteries, BA18 - see **Figure 1**

Check at regular intervals that the ventilation stub is undamaged and intact. The construction of the ventilation stub permits battery gasses to get out, but it does not permit penetration of water.

2. CS16 (TECHLINE™)

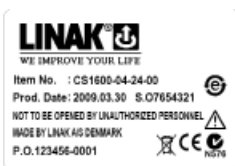

The CS16 electronic limit switch is connected between the LINAK® actuator and a non-LINAK power supply, where it cuts out the current to the actuator in end position of if an obstacle is encountered. The PCB contains a variable current limit setting and is available in different versions, depending on the actuator with which it is to be used.

The CS16 should be connected between the linear actuator and the power supply, where it will switch off the power when the actuator reaches end position or if the actuator is overloaded.

As the CS16 are open PCB's, they have to be installed in an encapsulation to prevent damage. (LINAK® offers one type of encapsulation for CS16).

Adjustment of CS16

The CS16 has a rotary potentiometer for adjusting the value of the cut-off current. To obtain the correct cut-off current, connect the CS16 and turn the potentiometer as far as it will go/anticlock wise to set the maximum cut-off current.

Then subject the actuator to the maximum load it will be exposed to in the application. At the same time turn the potentiometer clockwise, reducing the cut-off current, until the actuator stops (not in end position).

Then turn the potentiometer approx. quarter of a turn anti-clockwise and the system is ready for use.

As the CS16 is a open PCB's, it have to be installed in an encapsulation to prevent damage. (LINAK® offers one type of encapsulation).

3. DJB (MEDLINE® CARELINE®)



The DIN Junction Box is designed for use where there is a need for more than 1 or 2 controls to be connected to a control box.

The DIN Junction Box is constructed for connection of up to 4 controls with 8-pin DIN plugs. Furthermore, the box is constructed so that all channels for connection are placed on the same side of the box.

This gives the box a clean design and makes it easy to mount e.g. in a bed frame.

4. MJB (MEDLINE® CARELINE®)



The MJB (Modular Junction Box) is designed for use together with the CB20 and other OpenBus™ control boxes.

The MJB makes it possible to connect handsets, attendant controls and accessories with the CB20/CB6S/CB16. The CB20 has 2 modular jack interfaces, but by using the MJB the connection possibilities are greatly increased. One "modular jack" channel is used for connecting to the control box.

5. SLS (MEDLINE® CARELINE®)



LINAK has designed a switch that can be mounted in connection with the 24V DC actuators: LA12, LA22, LA28, LA28S, LA31, LA32, or LA34 and a control box on e.g. a bed frame.

The Safety Limit Switch (SLS). The SLS Switch is primarily used as a Limit Switch in systems consisting of a control box, LA28/28S and/or LA32.

As an example the SLS can be installed on the actuator cable where it disconnects the actuator in either inward or outward direction when activated. The SLS can also be used as a signal control directly connected to a control box.

9. Repair and disposal

Repair

Only an authorised LINAK service centre should repair the LINAK actuator systems. Systems to be repaired under warranty must be sent to an authorised LINAK service centre.

In order to avoid the risk of malfunction, all actuator repairs must only be carried out by an authorised LINAK Service shop or repairers, as special tools and parts must be used.

If a system is opened by unauthorised personnel there is a risk that it may malfunction at a later date.

Spare parts

LINAK can supply spindle parts and motor parts as spare parts. Please indicate the designation from the label when ordering spare parts from your nearest authorised LINAK dealer.

Disposal of LINAK's products

LINAK's products may be disposed of, possibly by dividing them into different waste groups for recycling or combustion.

We recommend that our product is disassembled as much as possible at the disposal and that you try to recycle it. As an example of main groups within sorting of waste we can mention the following.

Metal, plastic, cable scrap, combustible material and collection for recoverable resources.

Some of these main groups can be sub-divided into groups e.g. metal can be divided into steel and aluminum or plastic can be divided into ABS and PP.

As an example of sorting we show you below, which recycling groups the different components in LINAK's products should be placed into:

Product	Component	Recycling group
Actuator:	Spindle and motor Plastic housing Cable	Metal scrap Plastic recycling or combustion Cable scrap or combustion
Control box:	PC-board Plastic housing Cable Transformer Batteries	Electronics scrap Plastic recycling or combustion Cable scrap or combustion Metal scrap Recoverable resources
Control:	Plastic housing Cable PC-board	Plastic recycling or combustion Cable scrap or combustion Electronics scrap

By now nearly all our moulded plastic units are provided with an internal code for plastic types and fibre content, if any.

Main groups of disposal:

Product main type	Metal scrap	Cable scrap	Electronic scrap	Plastic recycling or combustion	Remark
ACC			X	X	
ACK		X	X	X	
ACL		X	X	X	
ACM		X	X	X	
ACP		X	X	X	
ACO		X	X	X	
BA18				X	Battery
BA20			X	X	Lead battery
BAJ1			X		
BAJ2			X		
BB3	X				
BL1	X				
BL4	X				
CB12	X		X	X	
CB14	X		X	X	
CB16	X		X	X	
CB20	X	X	X	X	
CB6	X		X	X	
CB6S	X		X	X	
CB7			X	X	
CB8-A			X		
CB8-T			X		
CB9	X	X	X	X	
CBJ1			X		
CBJ2			X		
CBJC					
CBJH			X		
CBR1			X		
CH08			X		
CHJ2			X		
CS16		X	X		
COBO20					
CP20	X		X	X	
CU20			X	X	
DJB		X	X	X	
FS	X	X	X	X	Metalscrap because of FSR + FSR
FS2	X	X	X	X	

Product main type	Metal scrap	Cable scrap	Electronic scrap	Plastic recycling or combustion	Remark
HB20			X	X	
HB40		X	X	X	
HB50		X	X	X	
HB60		X	X	X	
HB70		X	X	X	
HL70		X	X	X	
HB80		X	X	X	
HL80		X	X	X	
IRO			X	X	
LA12	X	X	X	X	
LA22	X	X		X	
LA23					
LA27	X		X	X	
LA28	X	X	X	X	
LA29	X	X	X	X	
LA30	X	X		X	
LA31	X	X	X	X	
LA32	X				
LA34	X	X	X	X	
LA44	X	X	X	X	
LC2	aluminum extrusions, spindle, motor, end plates, fasteners	power cable, signal cable	PCB	glide pads, retainer clips, top frame, PCB housing	
LP2	X	X			
LP3	X	X			
LS	X		X	X	
LSD	X	X	X	X	
MBJ1/2/3	X				
MJB			X	X	
SLS		X	X	X	

Practical information:

ACC	Folie glued together with housing
ACK	No housing. Only folie with cable
ACL	Cannot be opened since it is welded together. When the cable has been cut-off it is disposed of as combustible waste
ACM	Cannot be opened since it is welded together. When the cable has been cut-off it is disposed of as combustible waste
ACP	Screw together
ACO	Folie glued together with housing
BA18	
BA20	Welded together
BAJ1	Glued and screwed together
BAJ2	Glued and screwed together
BB3	Outer tube (Alu) can be dismantled (screws)
BL1	
BL4	Plastic housing and the BB3 inside can be dismantled (screws)
CB12	Screw together
CB14	Screw together
CB20	Glued and welded together. Cannot be opened
CB6	Glued and screwed together
CB6S	Glued and screwed together
CB7	
CB8-A	Screw together
CB8-T	Screw together
CB9	Has to be unscrewed with a screw driver
CB16	Glued and screwed together
CBJ1	Glued and screwed together
CBJ2	Glued and screwed together
CBJC	
CBJH	Glued and screwed together
CBR1	
CH01	Welded together
CH08	Welded together
CHJ2	Glued and screwed together
CS16	Screw together, cut off can be adjusted
COBO20	
CP20	Glued and screwed together
CU20	Glued and screwed together
DJB	Cannot be opened since it is welded together. When the cable has been cut-off it is disposed of as combustible waste
FPP	Folie glued together with housing
FS	
FS2	

Practical information:

HB20	
HB40	Screw together
HB50	Screw together
HB60	Screw together
HB70	Cannot be opened since it is welded together. When the cable has been cut-off it is disposed of as combustible waste
HL70	Cannot be opened since it is welded together. When the cable has been cut-off it is disposed of as combustible waste
HB80	Glued together
HL80	Glued together
IRO	Welded together
LA12	
LA22	Cannot be opened since it is glued together. When the cable has been cut-off it is disposed of as steel scrap
LA23	
LA27	Cannot be opened since it is welded together.
LA28	The outer tube is glued in the motor base, but it can be unscrewed with a pipe wrench in a vice
LA29	
LA30	
LA31	
LA32	The outer tube is glued in the motor base, but it may be unscrewed with a pipe wrench in a vice
LA34	
LA44	
LC2	<ul style="list-style-type: none">- LC2-2 uses an LA28 actuator and the LC2-5 uses an LA30 actuator- LC2 uses its own limit switch end-stop technology not the actuator current cut-off end-stop technology- LC2 assemblies should not be repeatedly disassembled because the screws are self-tapping and may compromise the fastener integrity
LP2	Lifting columns with gas spring may only be opened when they have run out to full stroke. They can be recognised by the 9 th figure, which is a "G" and by a warning label on the end plate
LP3	
LS	
LSD	
MBJ1/2/3	
MJB	Cannot be opened since it is welded together.
SL5	Cannot be opened since it is welded together. When the cable has been cut-off it is disposed of as combustible waste

Figure 1

Ventilation of external batteries, BA18

Check at regular intervals that the ventilation stub is undamaged and intact. The construction of the ventilation stub permits battery gasses to get out, but it does not permit penetration of water.

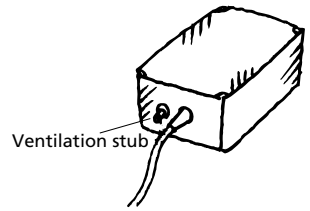

Figure 2

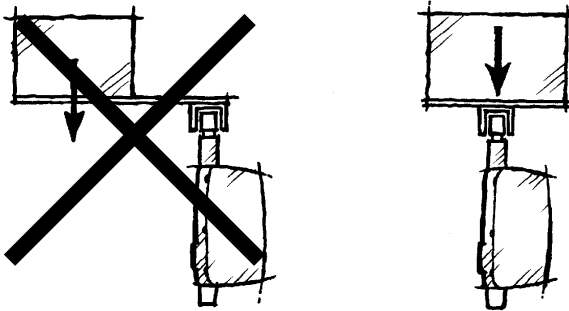

Figure 3

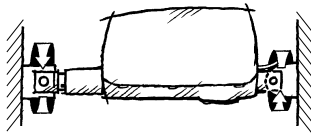

Figure 4

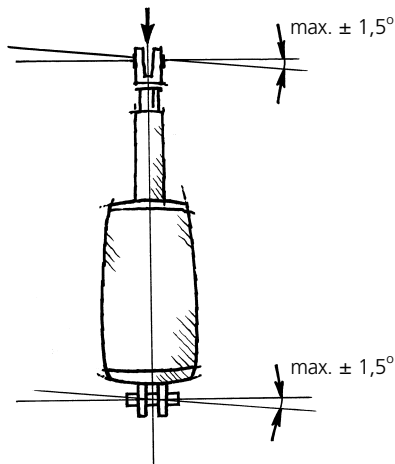
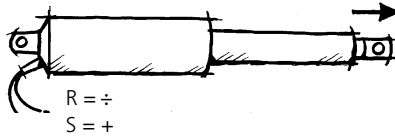
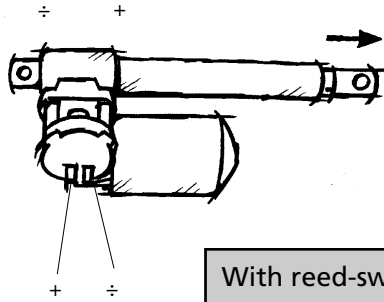

Figure 6

1) LA22



3) LA30 and 30S



4) LA12

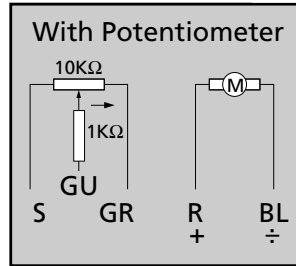
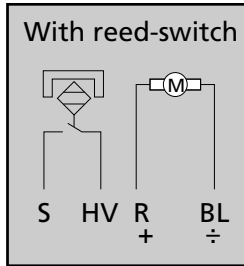
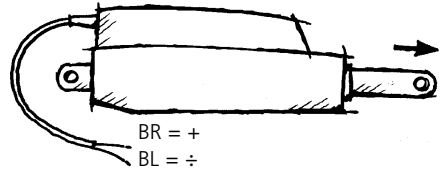

5) LA30, LA30S, LA32 and LA34 with potentiometer

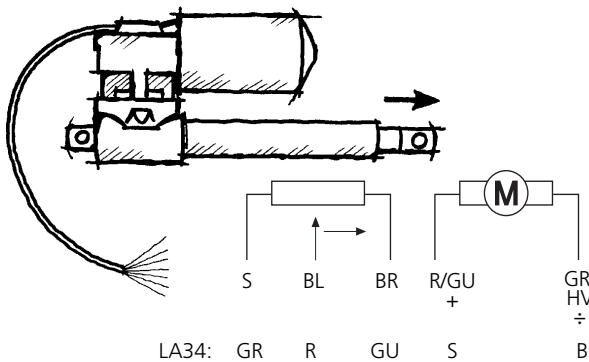

Colour codes:

S	Black
BR	Brown
R	Red
O	Orange
GU	Yellow
G	Grey
BL	Blue
V	Purple
GR	Green
HV	White

Figure 6 continued

6) LA30, LA30S and LA32 with optical encoder

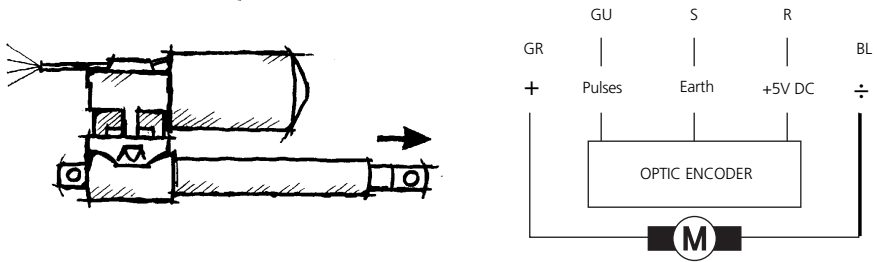

7A-B) LA28/28S/32 with CS28/28S/32 - PC-board version A and B

Version A

LINAK handset HB is connected with a telephone plug

Version B

LINAK handset HB is connected with a DIN plug

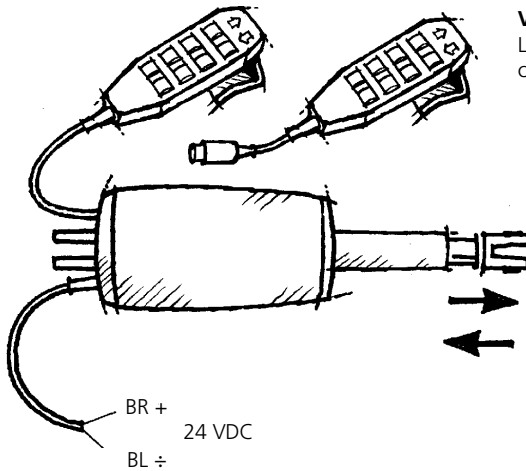

7C) LA28/28S/32 with CS28/28S/32 - PC-board version C

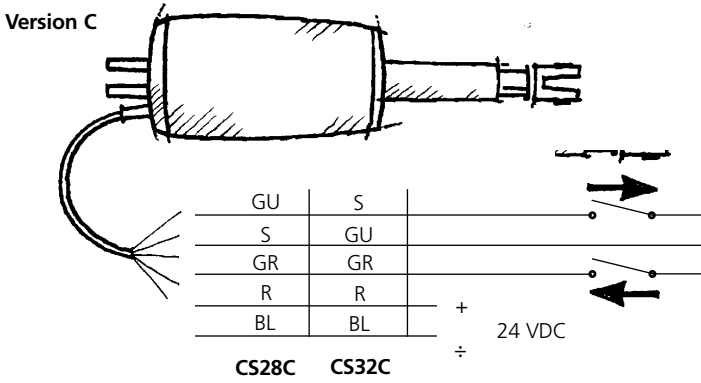

8) LA28, LA28S, LA32 with reed-switch and LA34 with pulse system

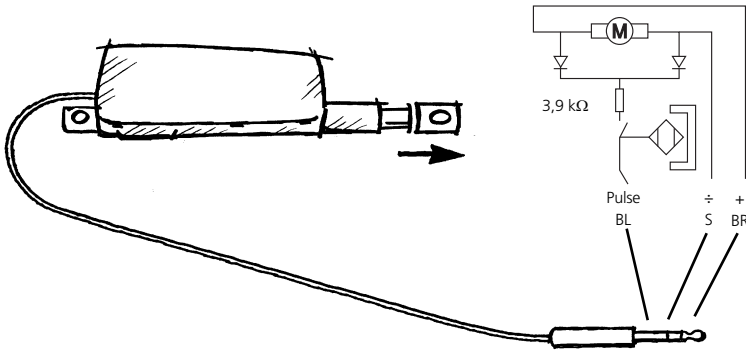

9) LSD

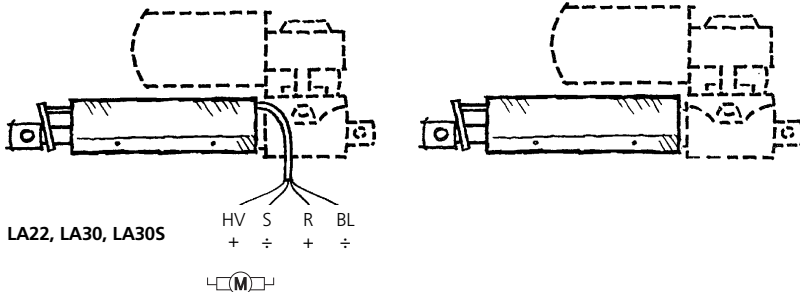

10) LA31, LA34 with electronic pulse coder (reed-switch)

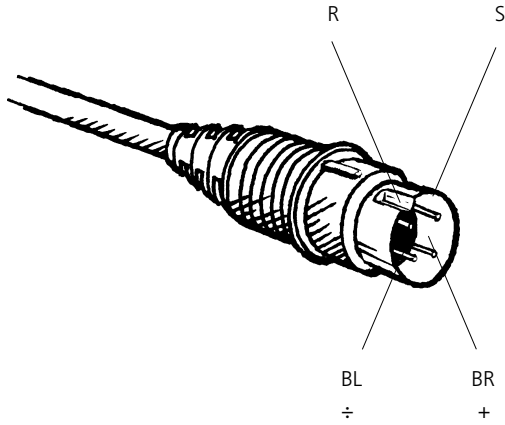

11) LA31 TECHLINE

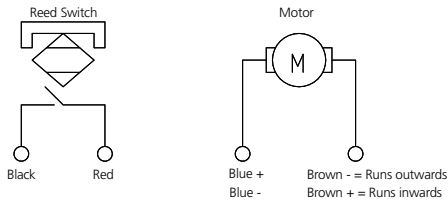

12) LA12 PLC

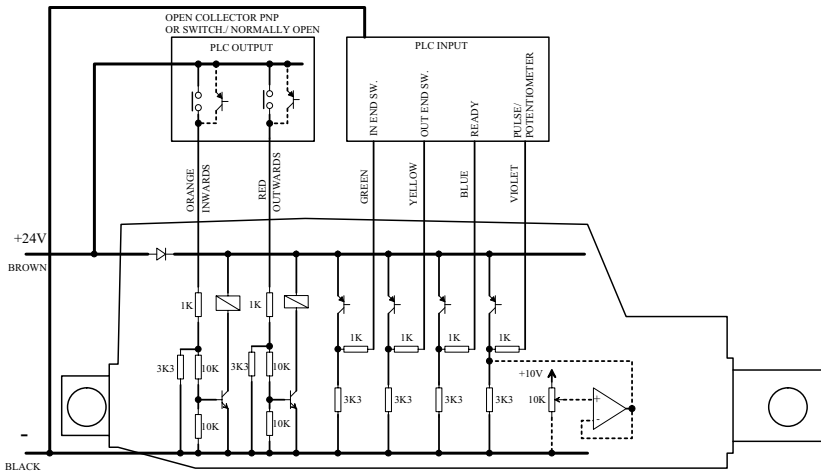
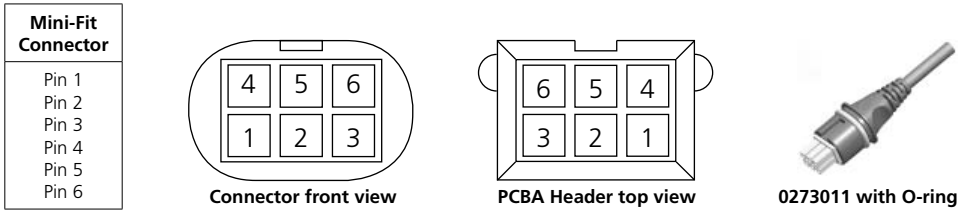

Figure 6 continued

13) Pin-connection for Mini-fit plug (valid for 13 and 14)



WITHOUT FEEDBACK

LA27 Mini-fit plug cable (LA27 standard; Valid for LA27 article numbers = 27xxxxxxxxxxxx0)

CH1-4 MiniFit:	
When a channel is operated UP (Motor connections)	3: Brown: + 6: Yellow: -
End-of-stroke switches	5: Orange: UP 4: Red: DOWN 2: Black: COMMON
Not Used	1: No Connection

(end of stroke = EOS)

LA23/LA31/LA34/BL1/BL4 Mini-fit plug cable

LA27 Mini-fit plug cable (Analog encoded without Hall)

without Feedback

without Feedback

Article numbers = 27xxxxxxxxxxxxB

EOS Switch	
Pin 1	Switch com. (GND)
Pin 2	Vbus
Pin 3	M+ (Motor/Power)
Pin 4	EOS out
Pin 5	EOD in
Pin 6	M- (Motor/Power)

EOS Switch	
Pin 1	Switch com. (GND)
Pin 2	Vbus
Pin 3	M+ (Motor/Power)
Pin 4	EOS out
Pin 5	EOD in
Pin 6	M- (Motor/Power)

WITH FEEDBACK

LA23/LA31/LA34/LA44/BL1 Mini-fit plug cable

LA27 Mini-fit plug cable

with Feedback

with Feedback

Article numbers = 27xxxxxxxxxxxxA

Hall	
Pin 1	Hall GND
Pin 2	Vbus
Pin 3	M+ (Motor/Power)
Pin 4	Hall A
Pin 5	Hall B
Pin 6	M- (Motor/Power)

Hall	
Pin 1	Hall com. (GND)
Pin 2	Vbus
Pin 3	M+ (Motor/Power)
Pin 4	EOS (analog)
Pin 5	Hall
Pin 6	M- (Motor/Power)

LA34/LA44 Mini-fit plug cable (potentiometer)

BL4 Mini-fit plug cable

Potentiometer

Reed

Potentiometer	
Pin 1	Pot GND
Pin 2	Vbus
Pin 3	M+ (Motor/Power)
Pin 4	Pot Position
Pin 5	Pot + (3V3)
Pin 6	M- (Motor/Power)

Reed	
Pin 1	Reed com. (GND)
Pin 2	Vbus
Pin 3	M+ (Motor/Power)
Pin 4	NC
Pin 5	Reed
Pin 6	M- (Motor/Power)

Figure 7

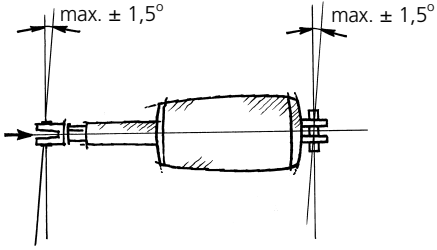

Figure 8

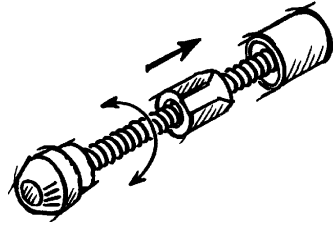

Figure 9

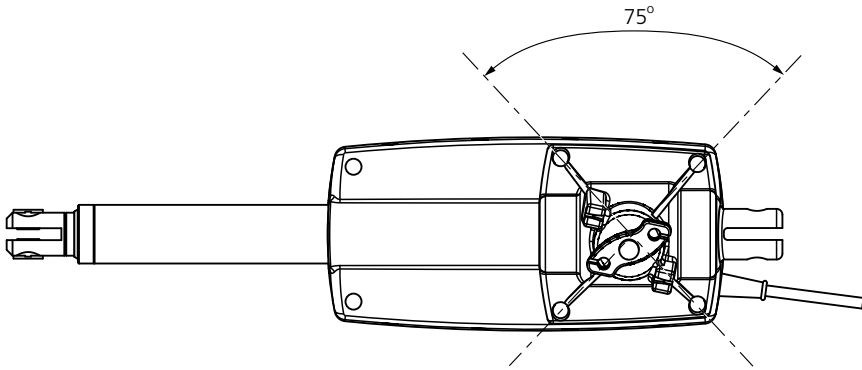
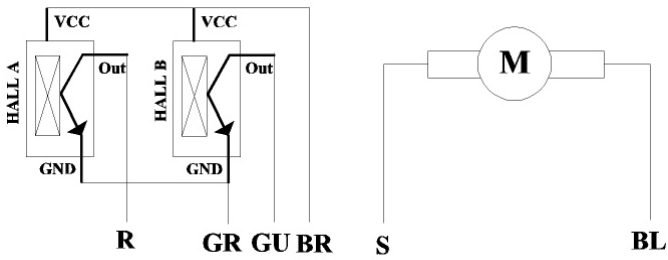

Figure 10



LINAK APPLICATION POLICY

The purpose of the application policy is to define areas of responsibilities in relation to applying a LINAK product defined as hardware, software, technical advice, etc. related to an existing or new customer application.

LINAK products as defined above are applicable for a wide range of applications within the Care and Health, Comfort furniture, Desk and Industry areas. Yet, LINAK cannot know all the conditions under which LINAK products will be installed, used, and operated, as each individual application is unique.

The suitability and functionality of the LINAK product and its performance under varying conditions (application, vibration, load, humidity, temperature, frequency, etc.) can only be verified by testing, and shall ultimately be the responsibility of the LINAK customer using any LINAK product. It is also the responsibility of the LINAK customer to make and supply a comprehensive User Manual of the application.

LINAK shall be responsible solely that the LINAK products comply with the specifications set out by LINAK and it shall be the responsibility of the LINAK customer to ensure that the specific LINAK product can be used for the application in question.

FACTORIES

CHINA

LINAK (Shenzhen) Actuator Systems, Ltd.
Phone: +86 755 8610 6656 · Fax: +86 755 8610 6990
E-mail: sales@linak.cn · www.linak.cn

DENMARK

LINAK A/S · Group Headquarters Guderup
Phone: +45 73 15 15 15 · Fax: +45 74 45 80 48
Fax (Sales): +45 73 15 16 13
E-mail: info@linak.com · www.linak.com

SLOVAKIA

LINAK Slovakia s.r.o.
Phone: +421 517563 414 · Fax: +421 517563 410
E-mail: jp@linak.sk · www.linak.com

USA

LINAK U.S. Inc.
North and South American Headquarters
Phone: +1 502 253 5595 · Fax: +1 502 253 5596
E-mail: info@linak-us.com · www.linak-us.com

SUBSIDIARIES

AUSTRALIA

LINAK Australia Pty. Ltd
Phone: +61 3 8796 9777 · Fax: +61 3 8796 9778
E-mail: sales@linak.com.au · www.linak.com.au

AUSTRIA

LINAK GmbH - Austria
Phone: +43 (0) 2266 61 9 62 · Fax: +43 (0) 2266 63 2 99
E-mail: info@linak.de · www.linak.at

BELGIUM & LUXEMBOURG

LINAK Actuator-Systems NV/SA
Phone: +32 (0) 230 01 09 · Fax: +32 (0) 230 88 80
E-mail: info@linak.be · www.linak.be

BRAZIL

LINAK DO BRASIL COMÉRCIO DE ATUADORES LTDA.
Phone: +55 (11) 2832-7070 · Fax: +55 (11) 2832-7060
E-mail: info@linak.com.br · www.linak.com.br

CANADA

LINAK Canada Inc.
Phone: +1 502 253 5595 · Fax: +1 905 821 4281
E-mail: info@linak.ca · www.linak.ca

CZECH REPUBLIC

LINAK C&S S.R.O.
Phone: +420581741814 · Fax: +420581702452
E-mail: ponizi@linak.cz · www.linak.cz

DENMARK

LINAK DANMARK A/S
Phone: +45 86 80 36 11 · Fax: +45 86 82 90 51
E-mail: linak@linak-silkeborg.dk · www.linak.dk

FINLAND

LINAK OY
Phone: +358 10 841 8700 · Fax: +358 10 841 8729
E-mail: linak@linak.fi · www.linak.fi

FRANCE

LINAK FRANCE E.U.R.L.
Phone: +33 (0)2 4136 3434 · Fax: +33 (0)2 4136 3500
E-mail: linak@linak.fr · www.linak.fr

GERMANY

LINAK GmbH
Phone: +49 6043 9655 0 · Fax: +49 6043 9655 60
E-mail: info@linak.de · www.linak.de

INDIA

LINAK A/S Asian Representative Office
Phone: +91 120 4797013
E-mail: info@linak.in · www.linak.in

IRELAND

LINAK UK Limited
Phone: +44(0)121 544 2211 · Fax: +44(0)121 544 2552
E-mail: sales@linak.co.uk · www.linak.co.uk

ITALY

LINAK ITALIA S.r.l.
Phone: +39 02 48 46 33 66 · Fax: +39 02 48 46 82 52
E-mail: info@linak.it · www.linak.it

JAPAN

LINAK K.K.
Phone: +81 45 533 0802 · Fax: +81 45 533 0803
E-mail: linak@linak.jp · www.linak.jp

MALAYSIA

LINAK A/S Asian Representative Office
Phone: +60 4 210 6500 · Fax: +60 4 226 8901
E-mail: info@linak-asia.com · www.linak-asia.com

NETHERLANDS

LINAK Actuator-Systems B.V.
Phone: +31 76 5 42 44 40 · Fax: +31 76 5 42 61 10
E-mail: info@linak.nl · www.linak.nl

NEW ZEALAND

LINAK New Zealand Ltd.
Phone: +64 9580 2071 · Fax: +64 9580 2072
E-mail: nzsales@linak.com.au · www.linak.co.nz

NORWAY

LINAK Norge AS
Phone: +47 32 82 90 90 · Fax: +47 32 82 90 98
E-mail: info@linak.no · www.linak.no

POLAND

LINAK Polska
Phone: +48 (22) 500 28 74 · Fax: +48 (22) 500 28 75
E-mail: dkreh@linak.dk · www.linak.pl

SPAIN

LINAK Actuadores, S.L.U.
Phone: +34 93 588 27 77 · Fax: +34 93 588 27 85
E-mail: linact@linak.es · www.linak.es

SWEDEN

LINAK Scandinavia AB
Phone: +46 8 732 20 00 · Fax: +46 8 732 20 50
E-mail: info@linak.se · www.linak.se

SWITZERLAND

LINAK AG
Phone: +41 43 388 31 88 · Fax: +41 43 388 31 87
E-mail: info@linak.ch · www.linak.ch

TAIWAN

LINAK A/S Taiwan Representative Office
Phone: +886 2 250 80296 · Fax: +886 2 2508 3604
E-mail: info@linak.com.tw · www.linak.com.tw

TURKEY

LINAK A/S Turkey Representative Office
Phone: +90 312 4726338-59 · Fax: +90 312 4726635
E-mail: vozen@linak.com.tr · www.linak.com.tr

UNITED KINGDOM

LINAK UK Limited
Phone: +44(0)121 544 2211 · Fax: +44(0)121 544 2552
E-mail: sales@linak.co.uk · www.linak.co.uk

DISTRIBUTORS

ARGENTINA

NOVOTEC ARGENTINA SRL
Phone: +[54] (11) 4303-8900/89 · Fax: +[54] (11) 4032-0184
E-mail: info@novotecargentina.com
www.novotecargentina.com

COLOMBIA

MEM Ltda
Phone: +[57] (11) 334-7666 · Fax: +[57] (11) 282-1684
E-mail: servicioalcliente@memltda.com.co
www.memltda.com.co

INDONESIA

PT. HIMALAYA EVEREST JAYA
Phone: +6 221 544 8956/65 · Fax: +6 221 619 4658/1925
E-mail: hejplastic-div@centrin.net.id · www.hej.co.id

IRAN

Bod Inc.
Phone: +98 2188998635 · Fax: +98 2188954481
E-mail: info@bod.ir · www.bod.ir

MEXICO

ILSA S.A. de C.V.
Phone: +[52] (55) 5388-3960 · Fax: +[52] (55) 5388-3966
E-mail: linak@isamexico.com · www.isamexico.com

PERU

PERCY MARTIN DEL AGUILA UBILLIS
Phone: +51 99- 883-9879

RUSSIAN FEDERATION

000 FAM
Phone: +7 812 319333 · Fax: +7 812 3271454
E-mail: purchase@fam-drive.ru · www.fam-drive.ru

SINGAPORE

SERVO DYNAMICS PTE. Ltd.
Phone: +65 6844 0288 · Fax: +65 6844 0070
E-mail: servodynamics@servo.com.sg · www.servo.com.sg

SOUTH AFRICA

Industrial Specialised Applications CC
Phone: +27 11 312 2292 or +27 11 2077600
Fax: +27 11 315 6999
E-mail: gartht@isagroup.co.za · www.isaza.co.za

SOUTH KOREA

UNITEK ENG.
Phone: +82 2 567 0888 · Fax: +82 2 3453 1177
E-mail: unitekeng@unitekeng.co.kr · www.unitekeng.co.kr

UNITED ARAB EMIRATES

Mechatronics
Phone: +971 4 267 4311 · Fax: +971 4 267 4312
E-mail: mechtron@emirates.net.ae
www.mechtronics.ae

For contact details on other countries please visit
www.linak.com or contact:

LINAK INTERNATIONAL

Fax: +45 74 45 90 10
E-mail: info@linak.com · www.linak.com

Terms of use

The user is responsible for determining the suitability of LINAK products for specific application. LINAK takes great care in providing accurate and up-to-date information on its products.

However, due to continuous development in order to improve its products, LINAK products are subject to frequent modifications and changes without prior notice. Therefore, LINAK cannot guarantee the correct and actual status of said information on its products.

While LINAK uses its best efforts to fulfil orders, LINAK cannot, for the same reasons as mentioned above, guarantee the availability of any particular product. Therefore, LINAK reserves the right to discontinue the sale of any product displayed on its website or listed in its catalogues or other written material drawn up by LINAK.

All sales are subject to the Standard Terms of Sale and Delivery for LINAK. For a copy hereof, please contact LINAK.



WE IMPROVE YOUR LIFE