

## Main Wiring Diagram

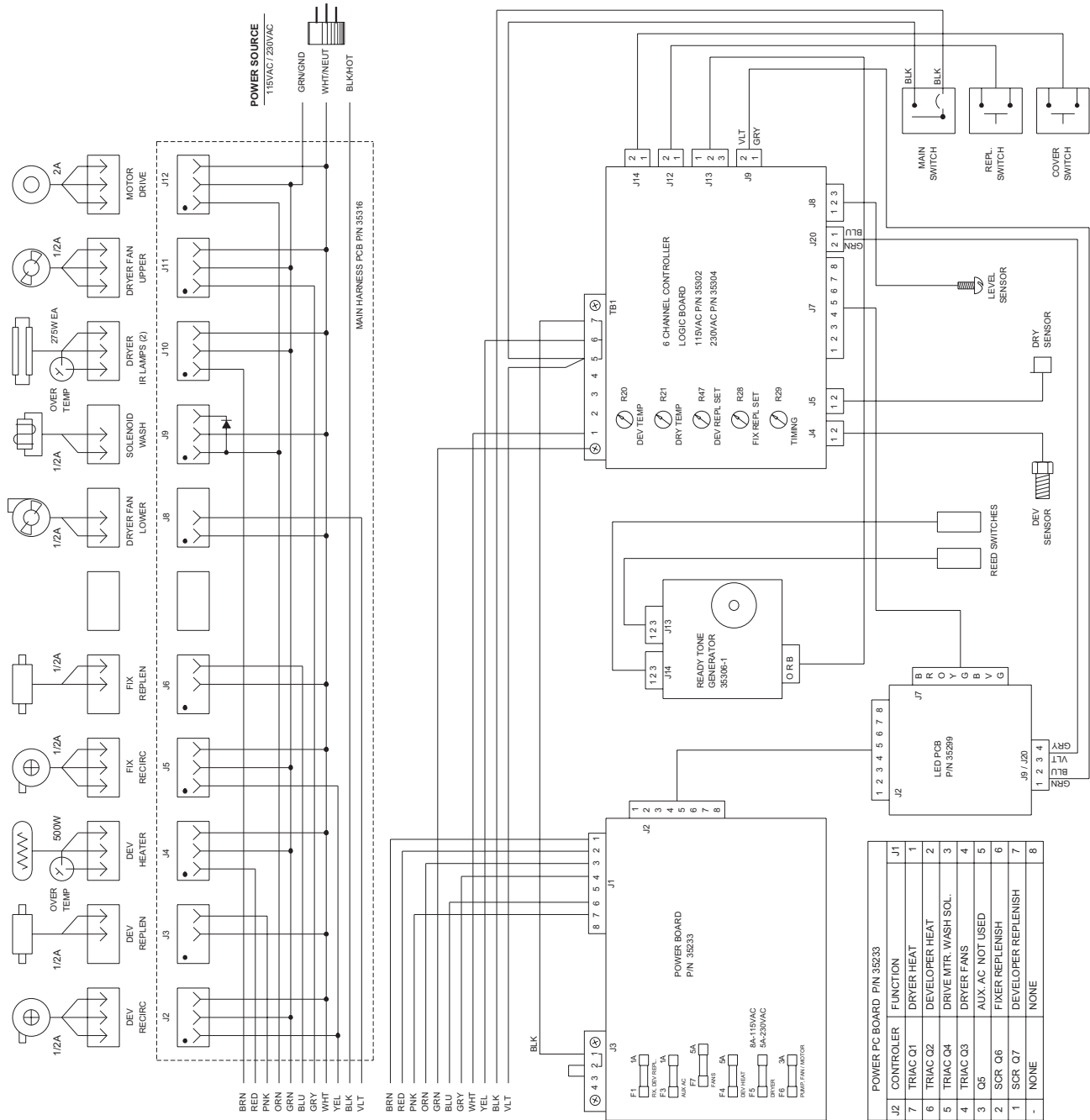

Figure 5-5, Main Wiring Diagram

# Dryer Rack Wiring Diagram

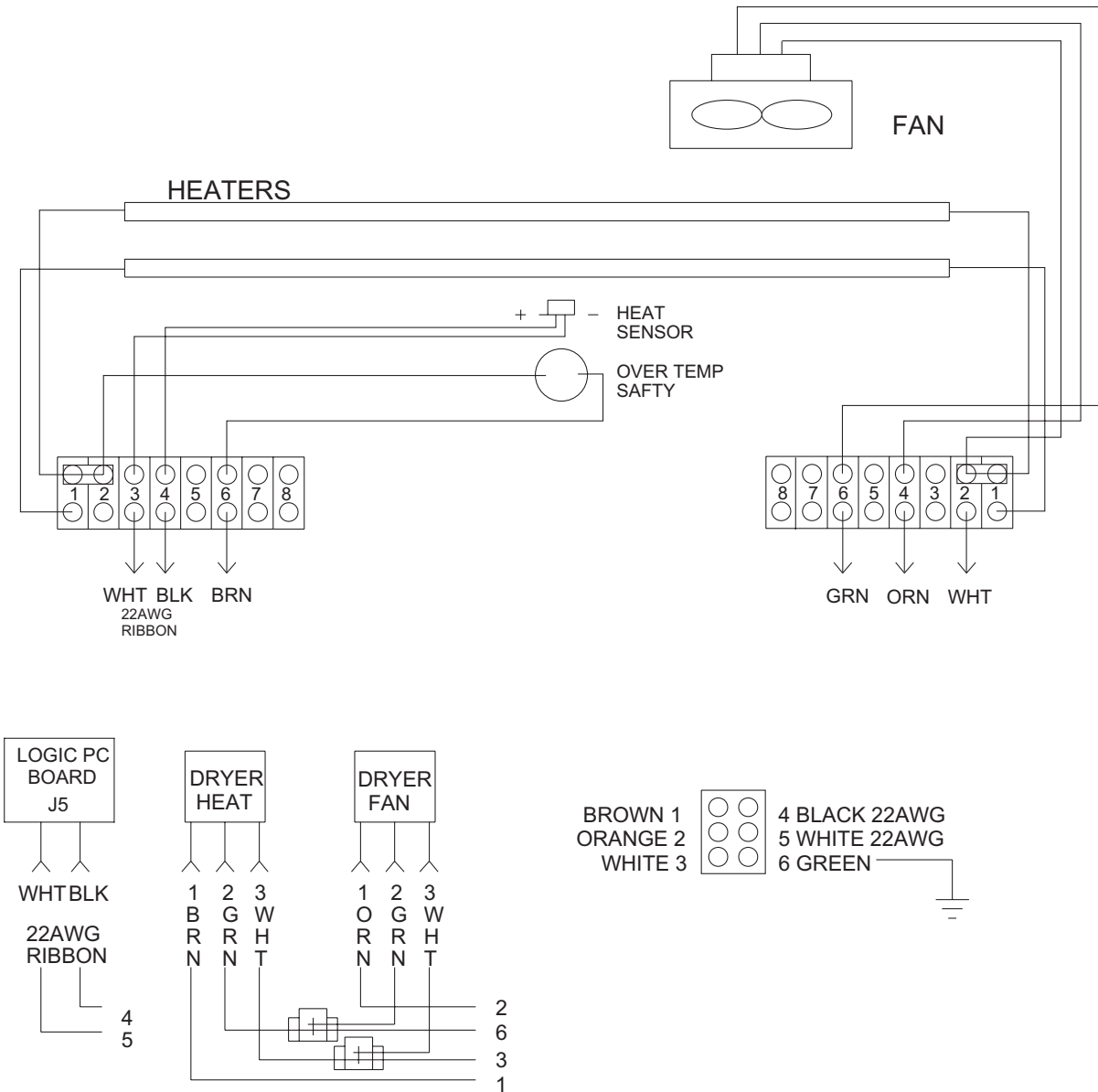

Figure 5-6, Dryer Rack Wiring Diagram

## AC Interface Board Schematic

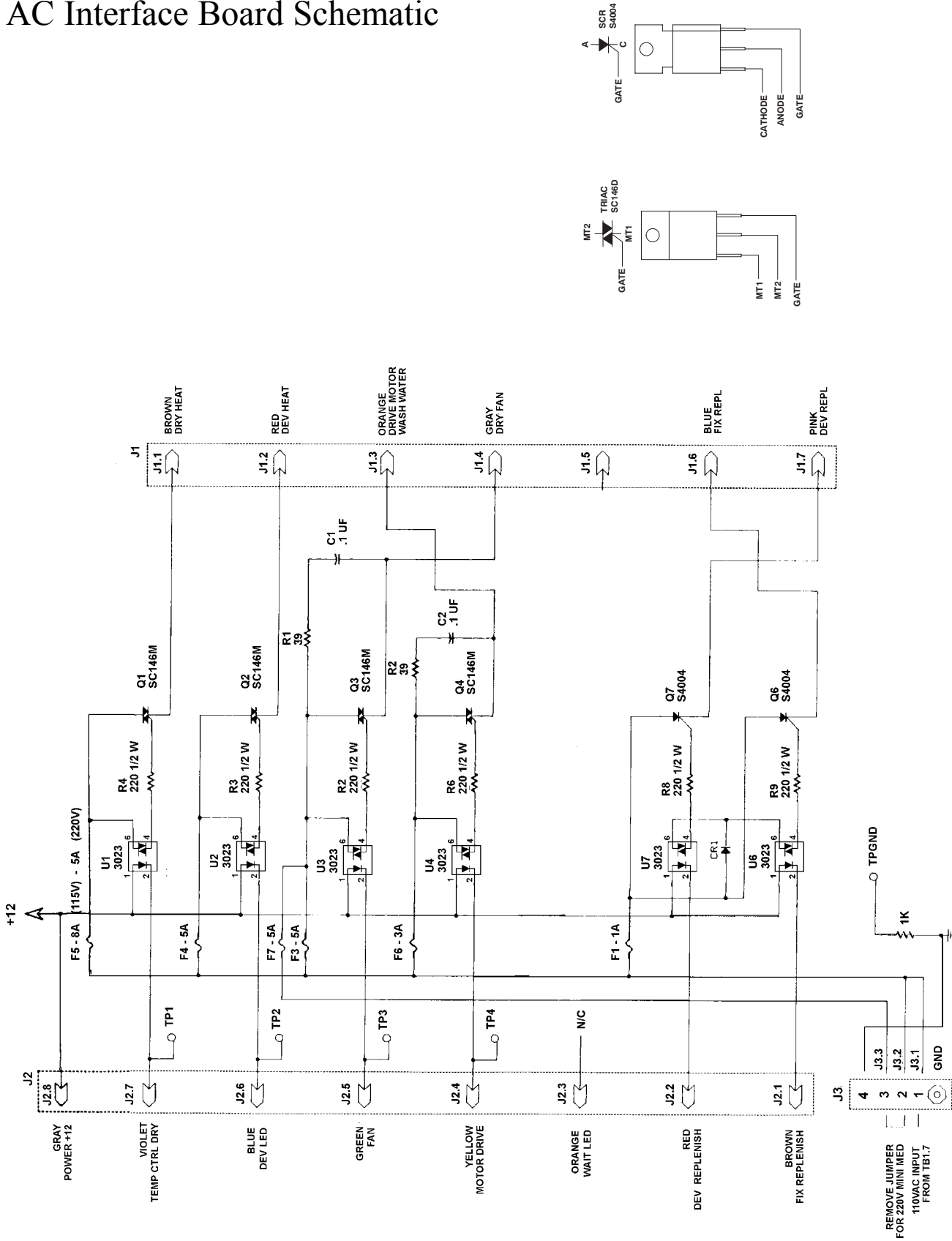

Figure 5-7, AC Interface Board Schematic

# Logic Board Schematic

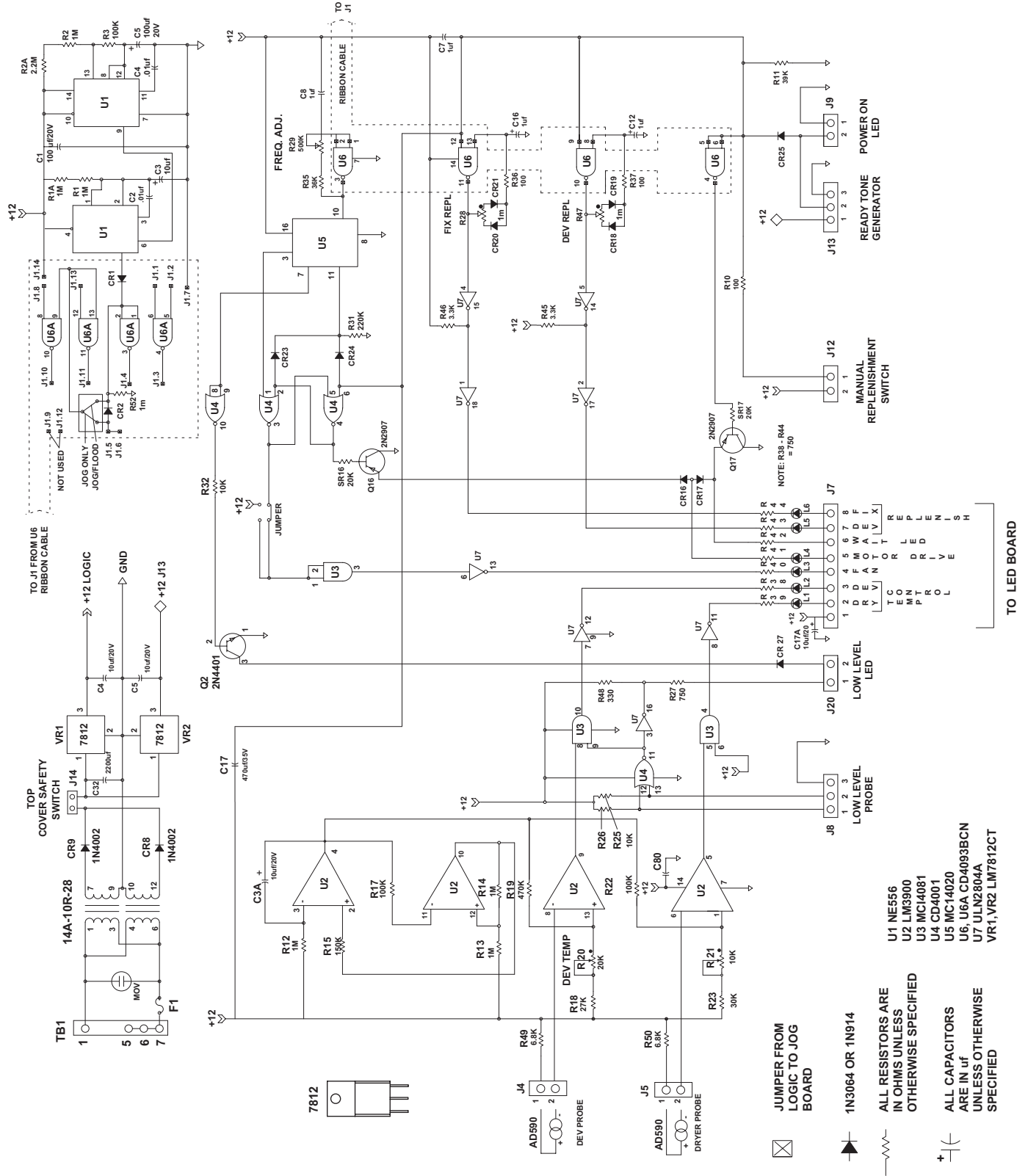

Figure 5-8, Logic Board Schematic

## Logic Board Layout

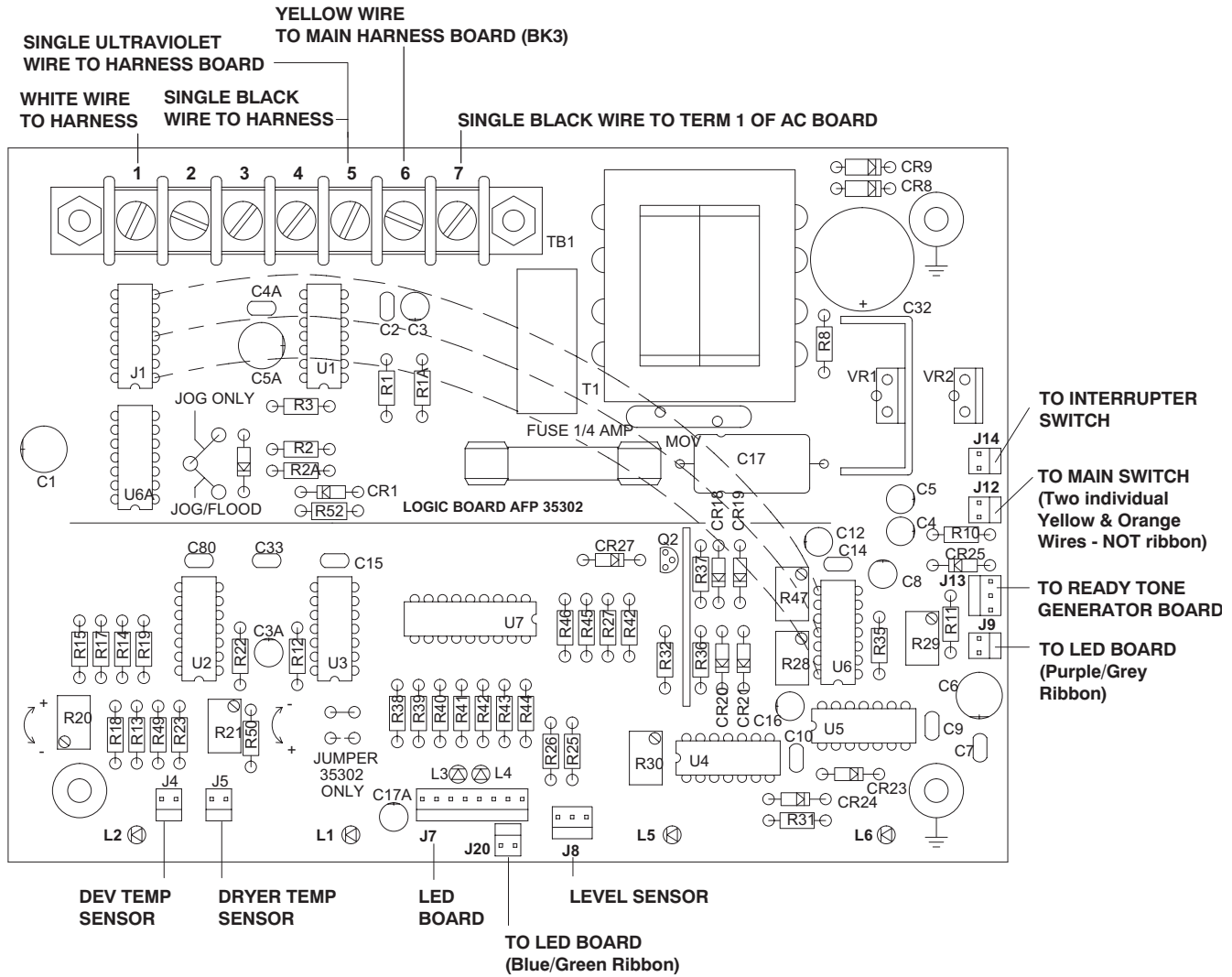

Figure 5-9, Logic Board Layout

# AC Interface Board Layout

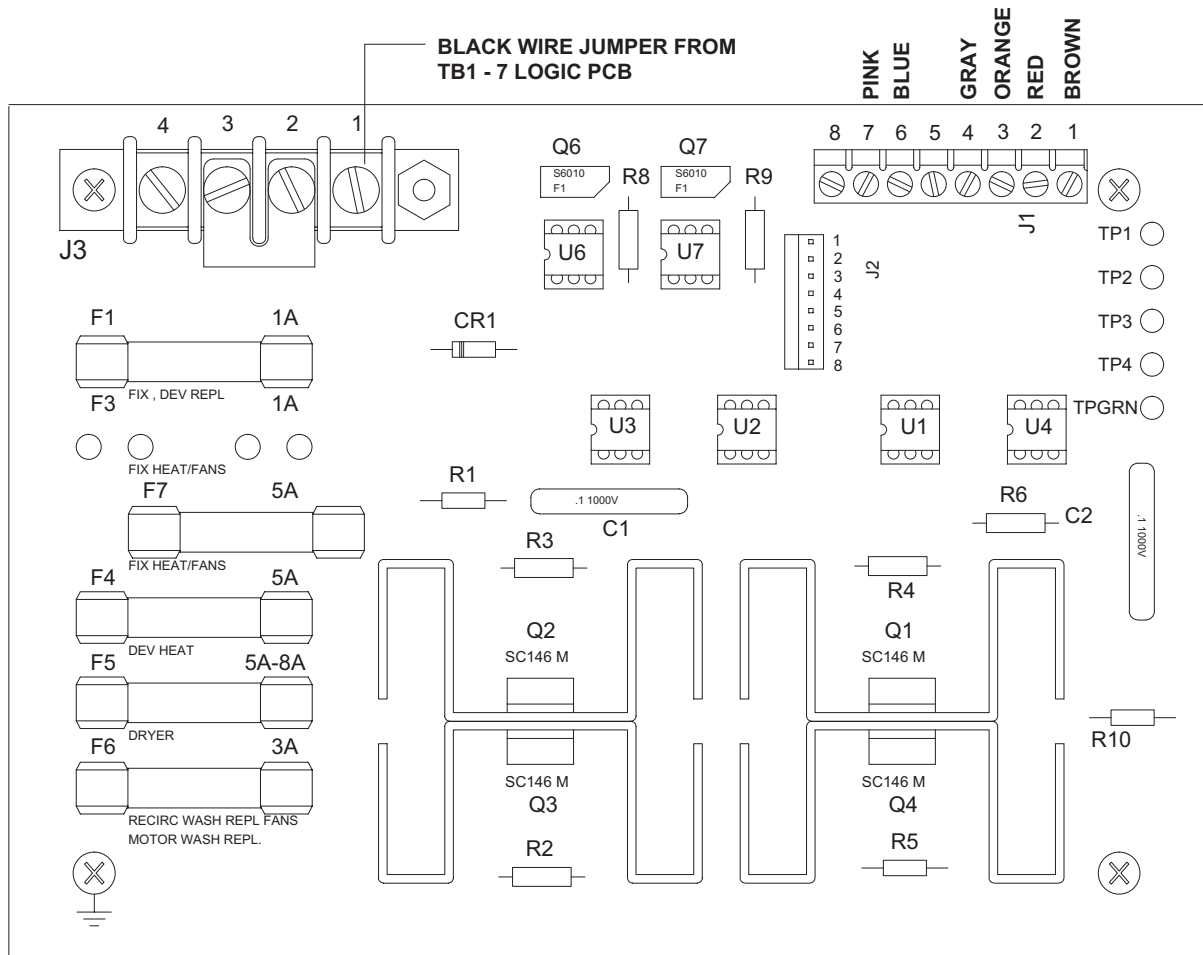

Figure 5-10, AC Interface Board Layout

## Ready Tone Generator Layout & Schematic

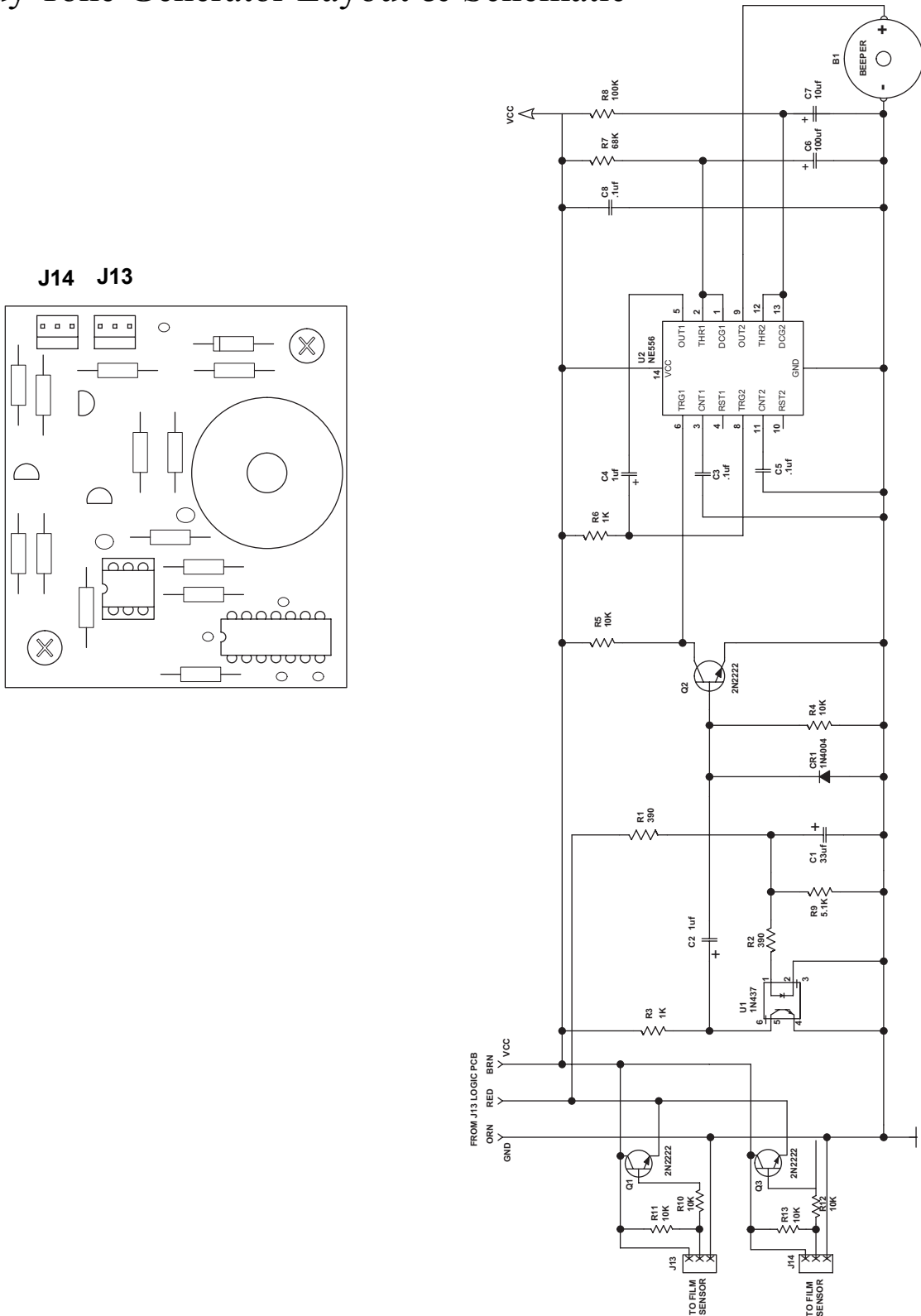

Figure 5-11, Ready Tone Generator Layout & Schematic  
(For Serial #'s 1900 And Higher)

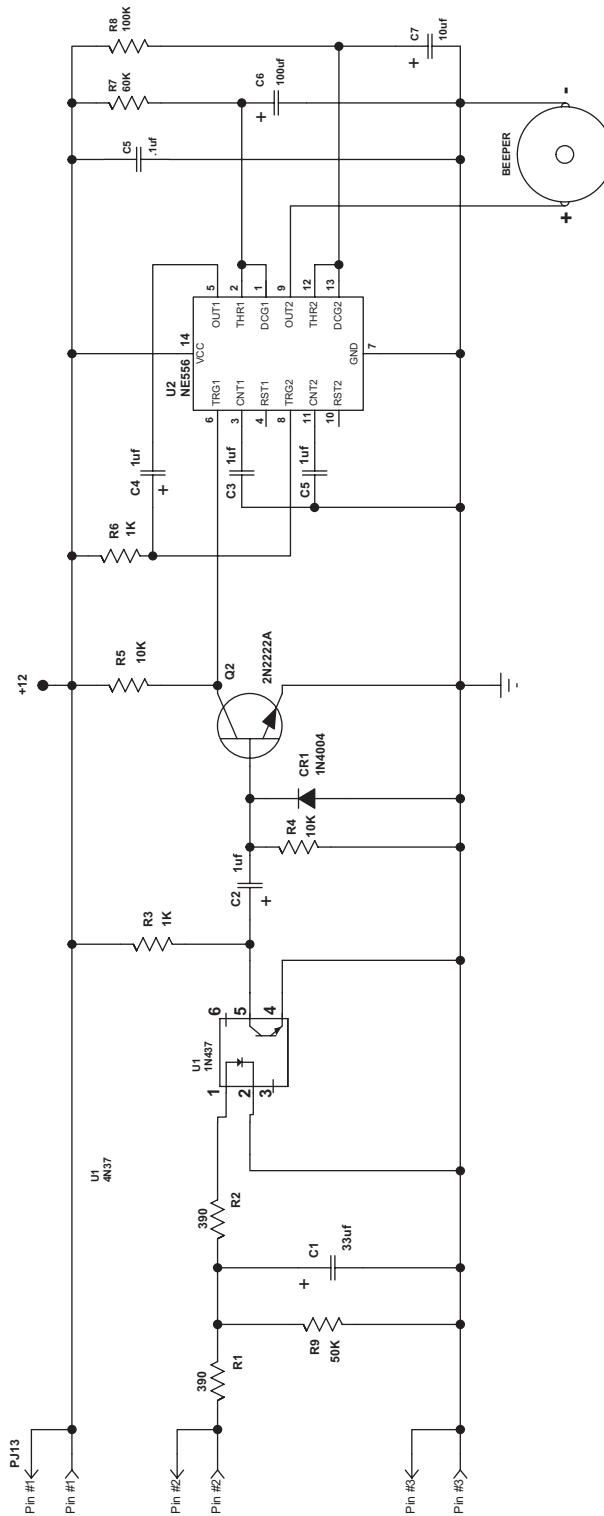

Figure 5-12, Ready Tone Generator Schematic  
(For Serial #'s Below 1900)



## LED Board Layout & Schematic

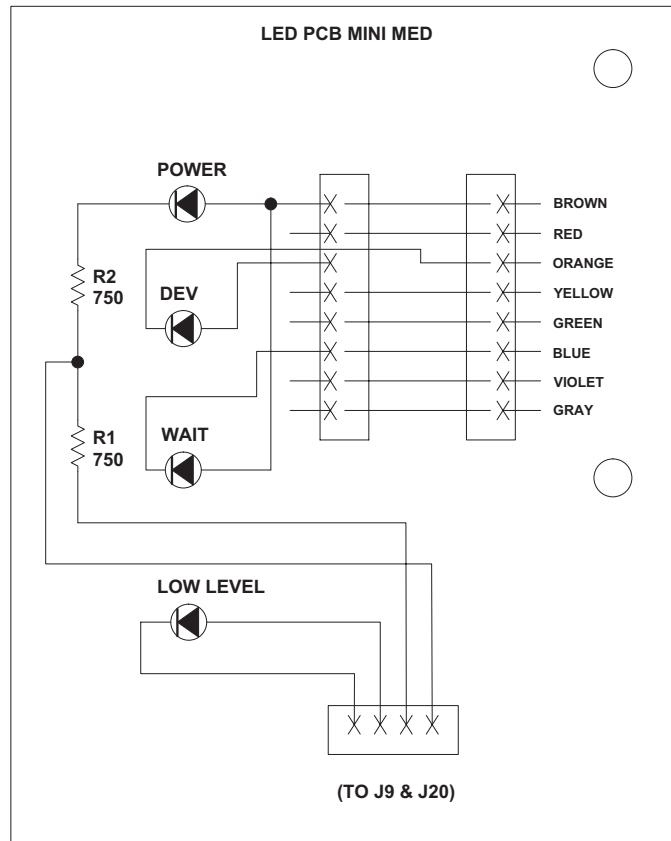
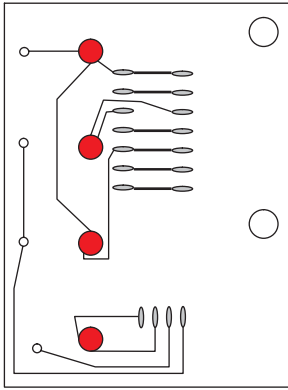

Figure 5-13, LED Board Layout & Schematic